

INSTALLING AND REPLACING STANDARD CUTTER BLADES

FIG. 1 - INSTALLATION OF CUTTER BLADE

The correct way to install the Cutter Blade is illustrated in Figure 1. *Note position of sharpened edge of blade.*

FIG. 2 - EDGE OF CUTTER BLADE WORN

A Cutter Blade in this worn condition needs to be replaced. *A worn blade will hinder the operation of digging. Compare with Blade in Figure 1.*

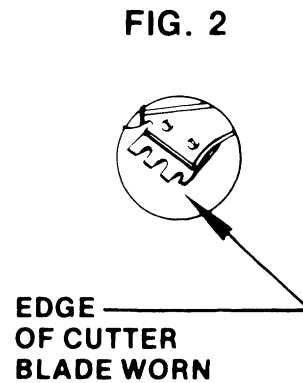
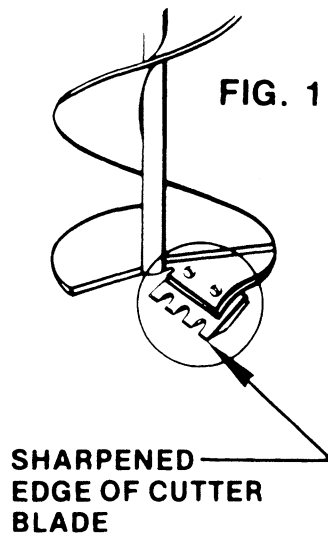

INSTALLING PENGU HEAVY DUTY AUGERS TEETH & PILOT POINTS

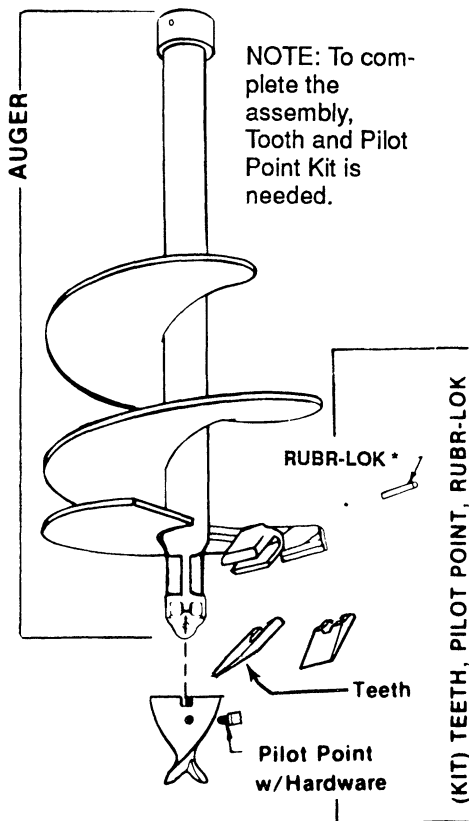

Quick-change teeth with RUBR-LOK*

