

PARTNER

Illustrated Parts List 2000-05 CD

K850 Mark II 1987-1998

K1200 Mark II 1987-1998

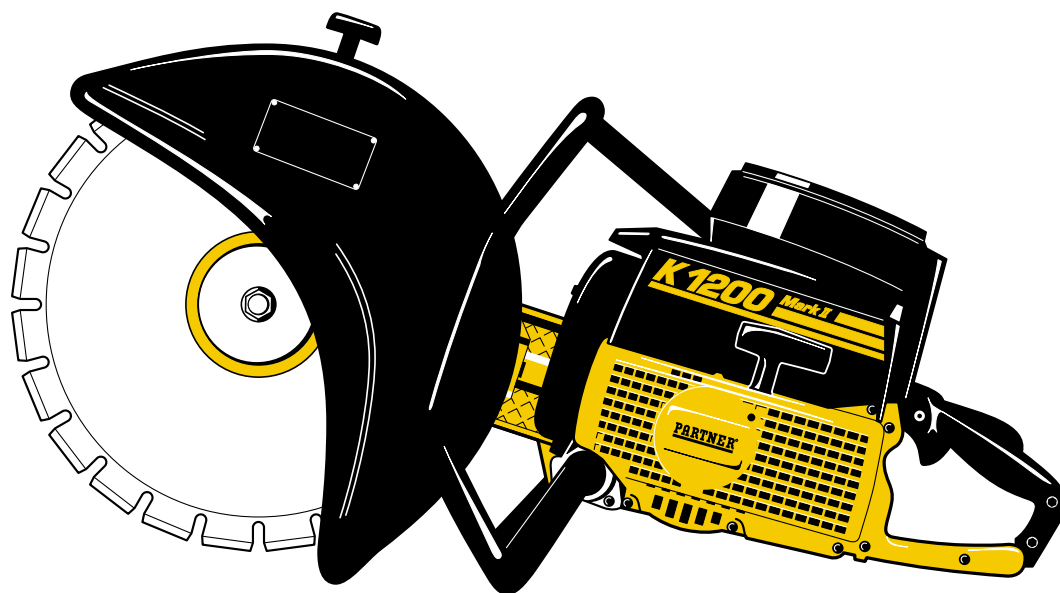

108 30 00-55

PARTNER®

A

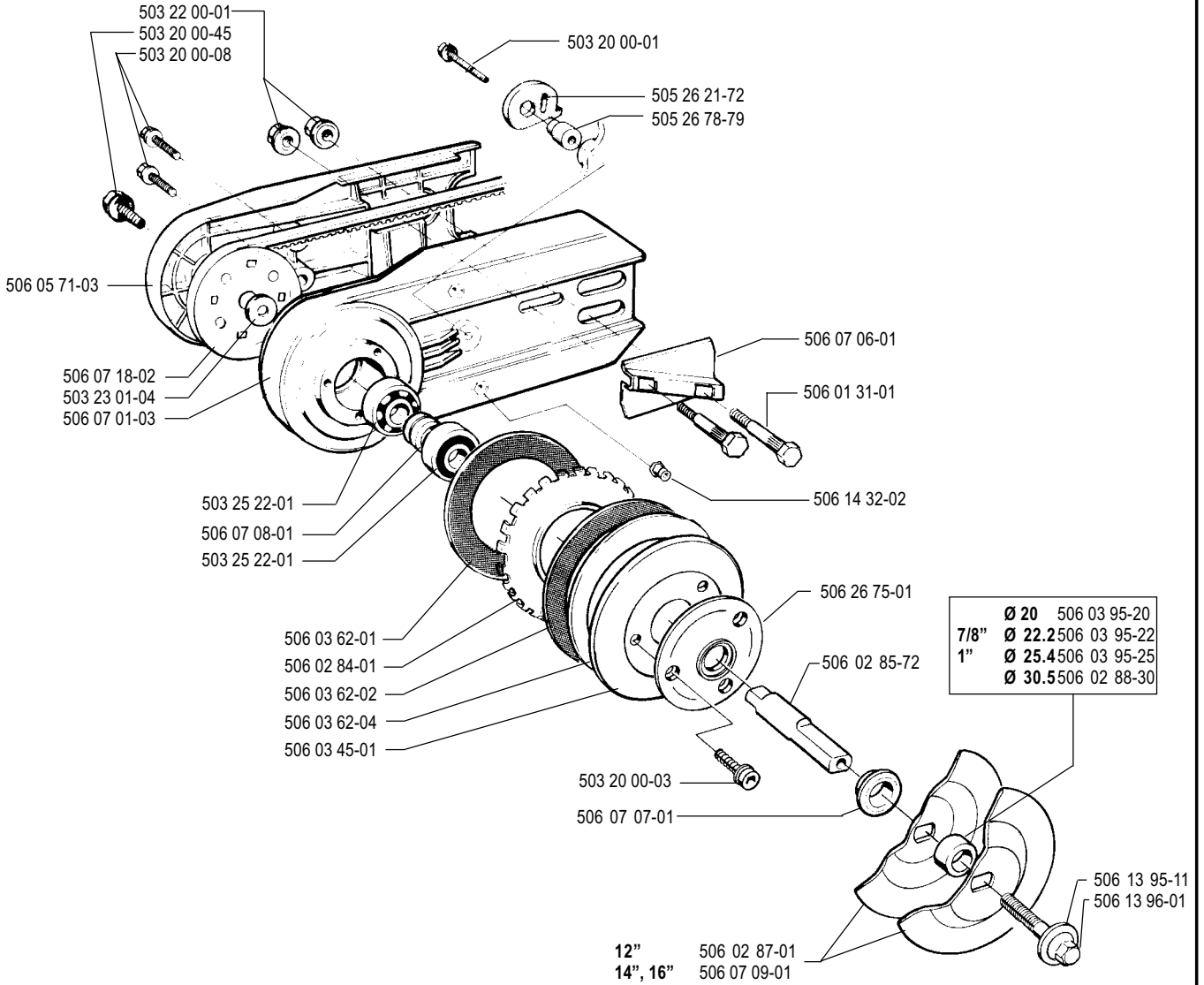

B

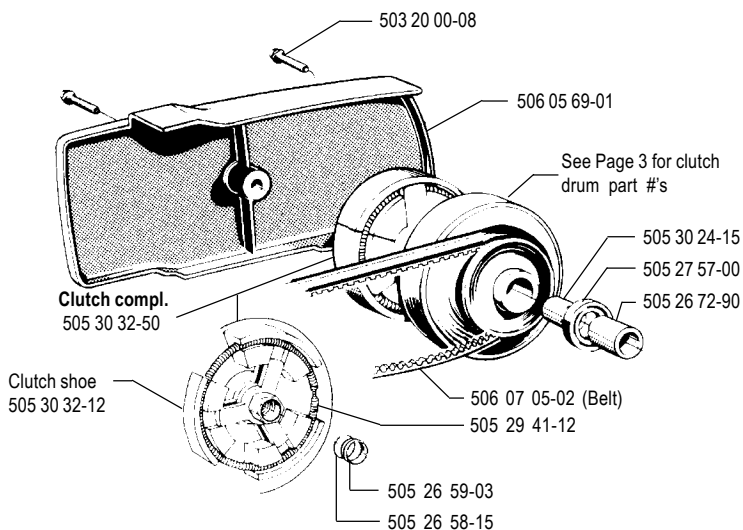

C

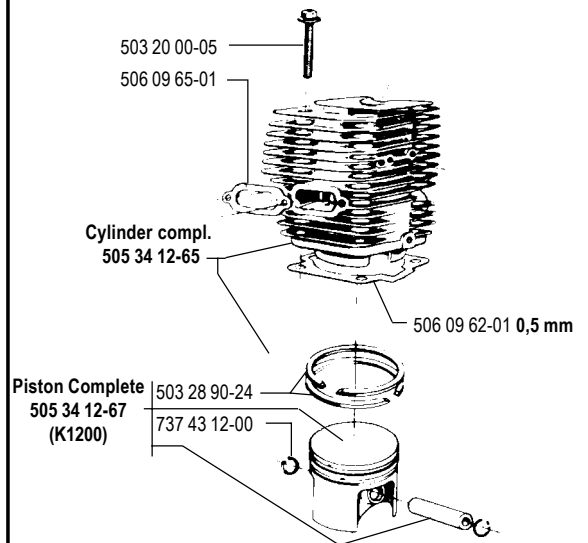

Note: All parts interchange with the model **K850 Mark II** except:
 Piston Complete K850 (52 mm bore) 505 34 08-12
 Piston Ring K850 503 28 90-19

D

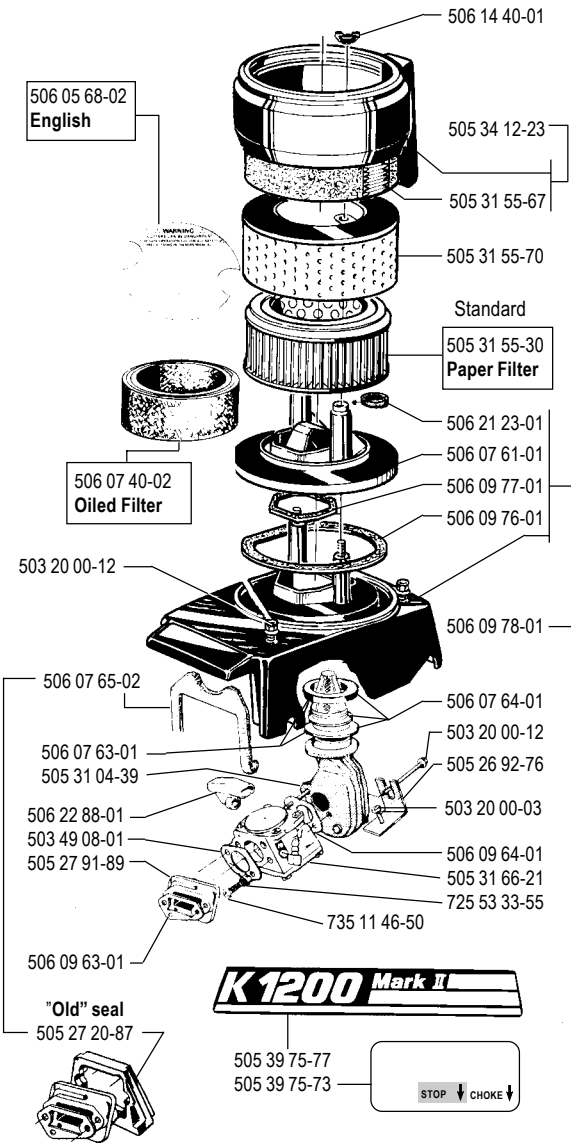

E

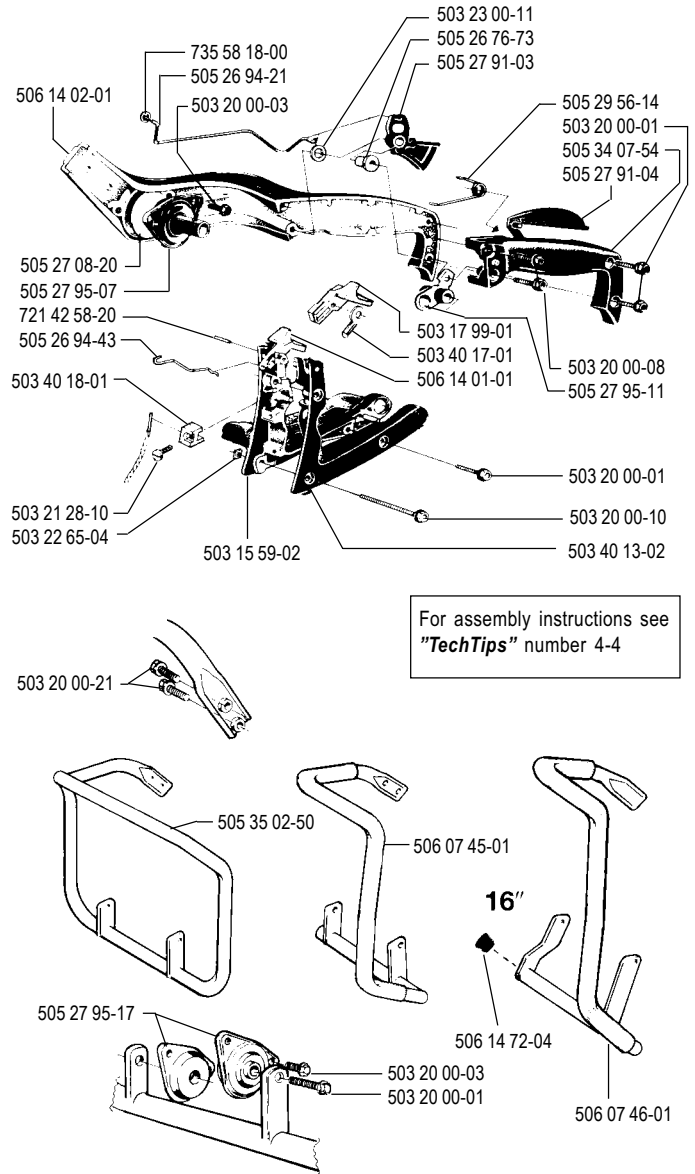

F

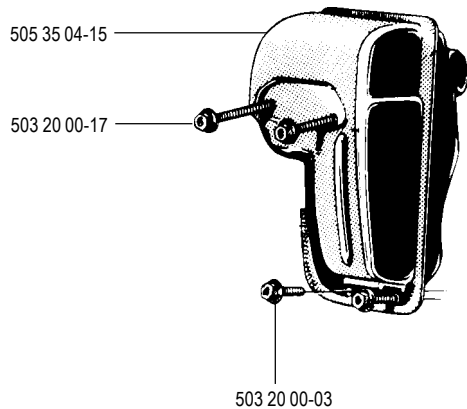

G

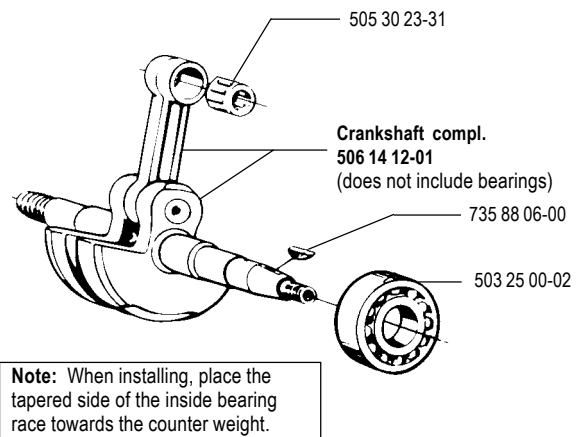

H12"/100 (red)
506 07 03-0312"/80 + 14"/100 (yellow)
506 07 03-02

506 02 98-02

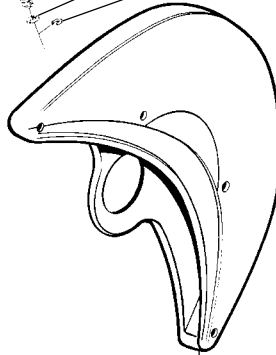
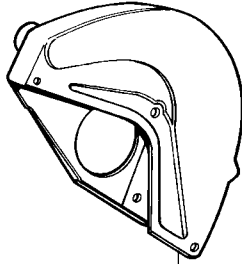
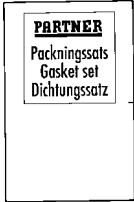
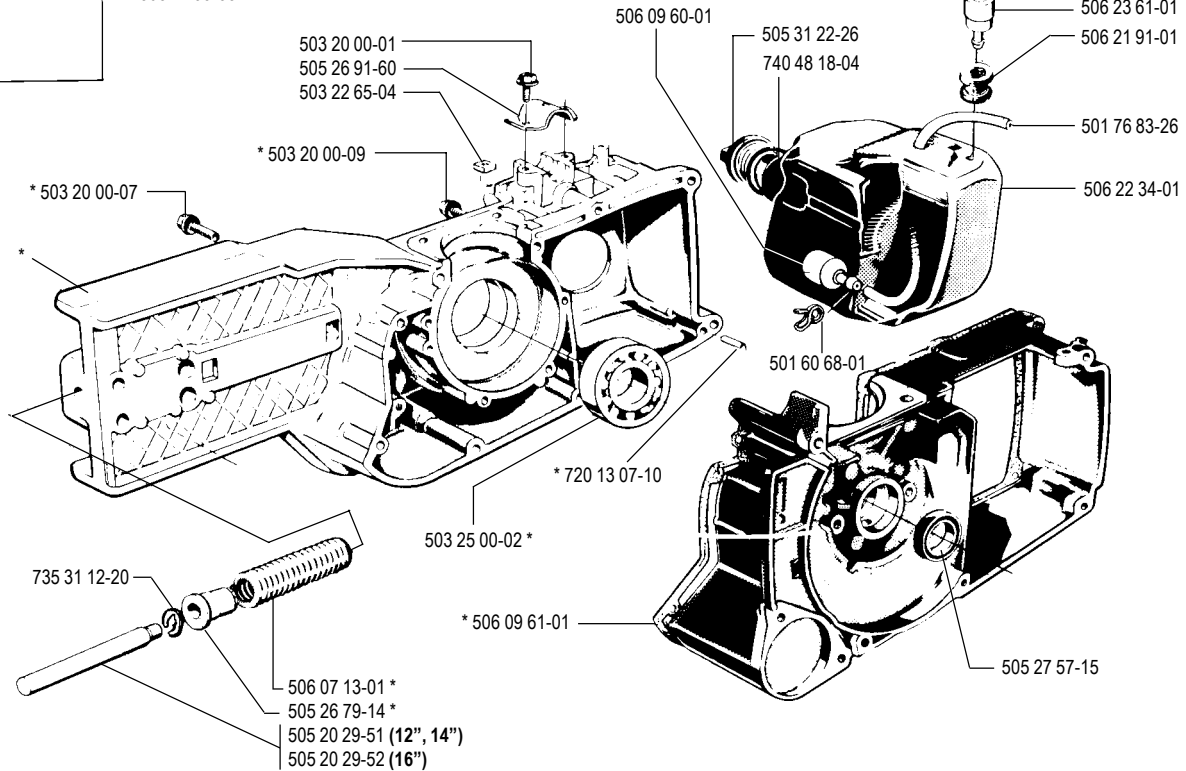
16" (blue)
506 07 03-04506 02 98-01
506 02 95-01
503 23 00-05
506 02 96-01
506 21 21-01
735 31 09-20506 02 98-04
506 02 95-03
503 23 00-05
506 02 96-01
506 21 21-01
735 31 09-20506 02 95-02
503 23 00-05
506 02 96-01
506 21 21-01
735 31 09-2012" Guard Cpl.
506 26 00-0214" Guard Cpl.
506 13 82-0116" Guard Cpl.
506 13 83-01**J*** Crankcase compl.
506 07 15-01Vent compl.
506 07 11-13Gasket Kit cpl.
505 27 99-35

K

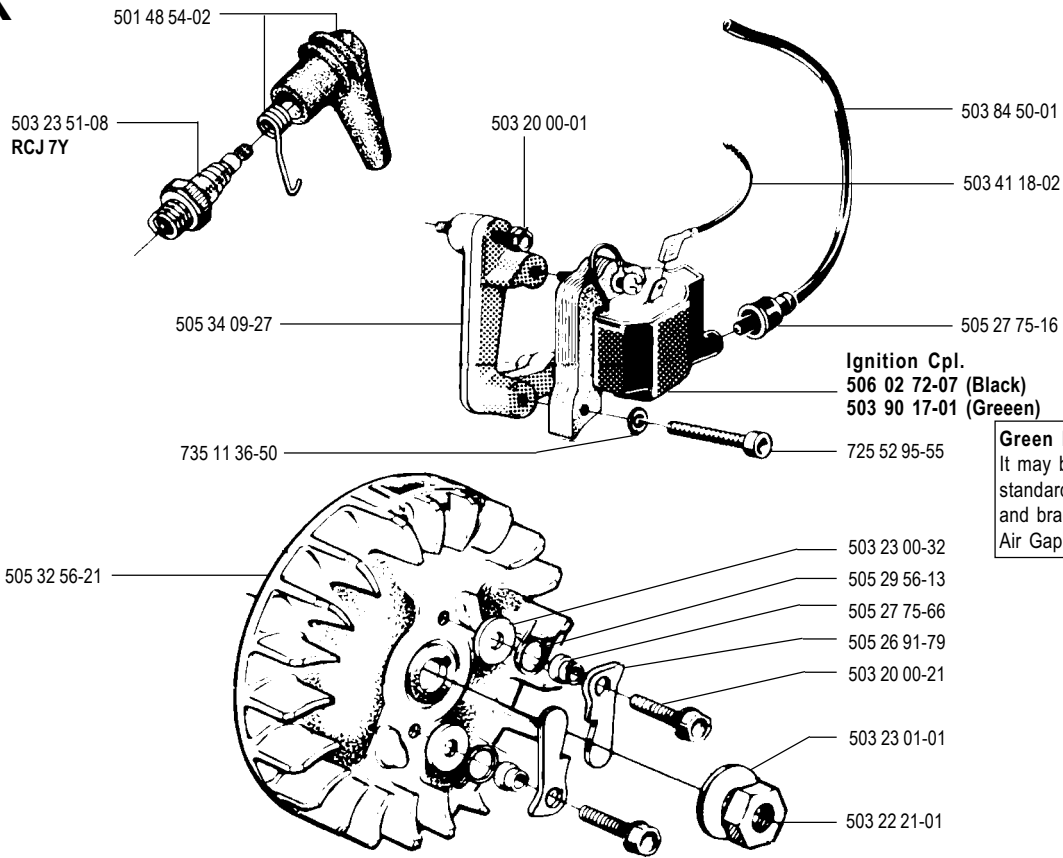

Ignition Cpl.
 506 02 72-07 (Black)
 503 90 17-01 (Green)

Green Ignition:
 It may be necessary to use a standard washer between the ign. and bracket for proper alignment.
 Air Gap approx.: 0.4 mm / .015"

L

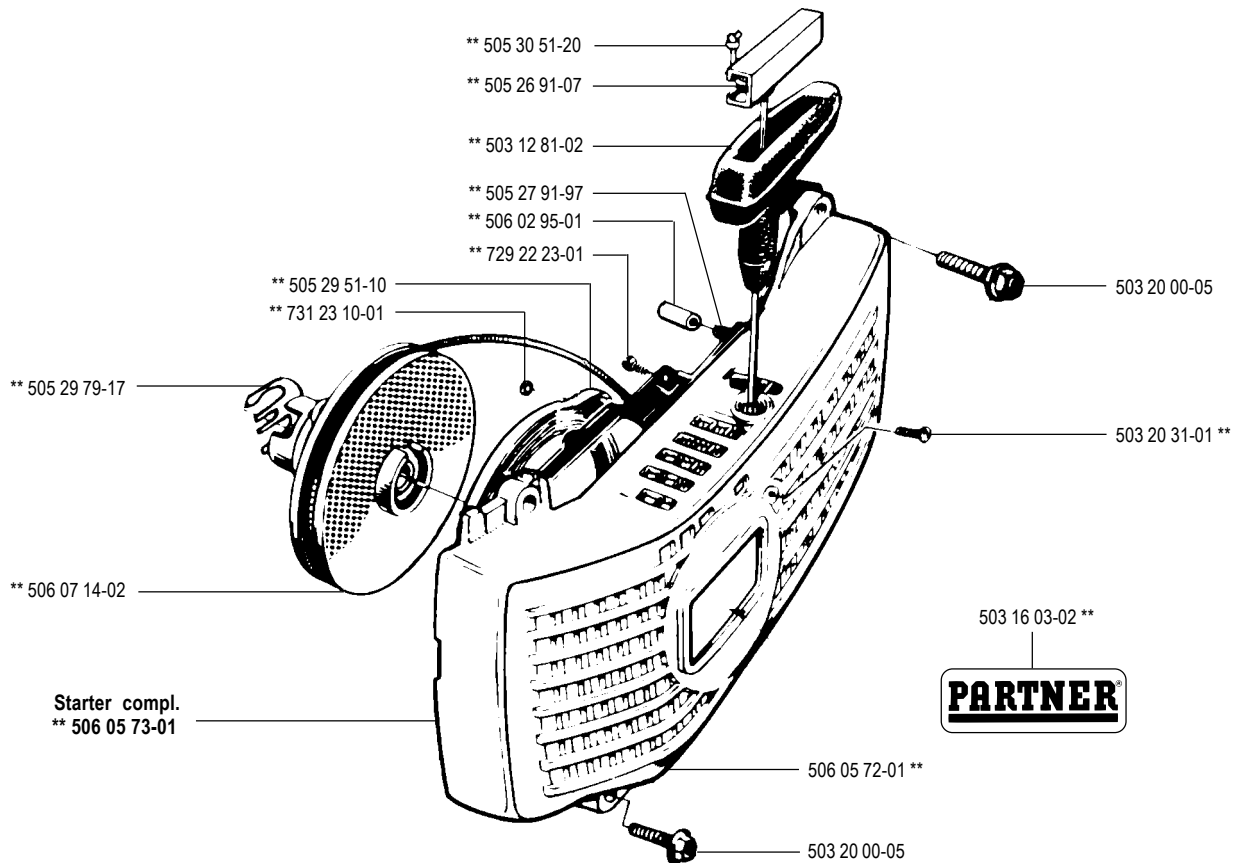

Starter compl.
 ** 506 05 73-01



M

Carburetor compl. 505 31 66-21
Tillotson HS 175 D

Repair kit
RK 31HS

506 27 63-01

Diaphragm and gasket set

506 25 88-01

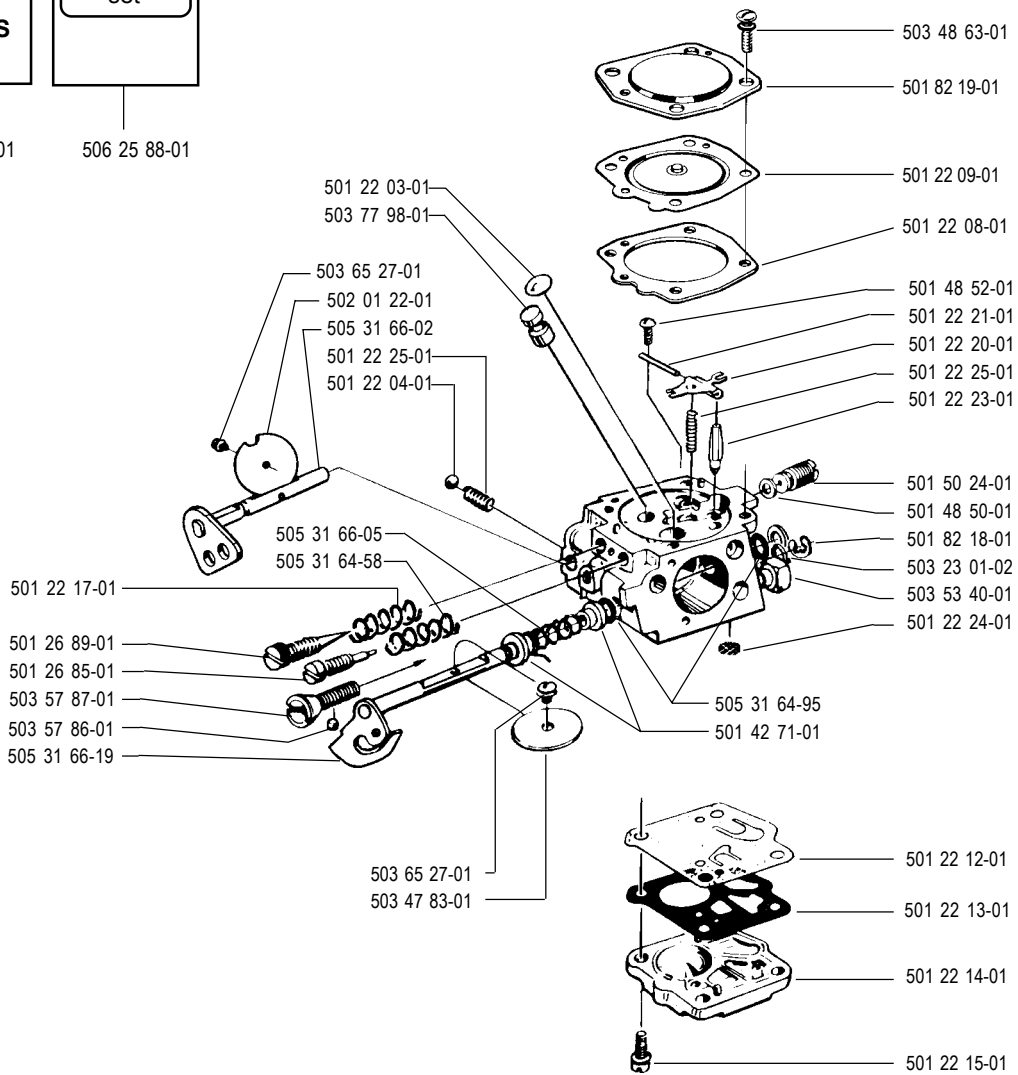

N

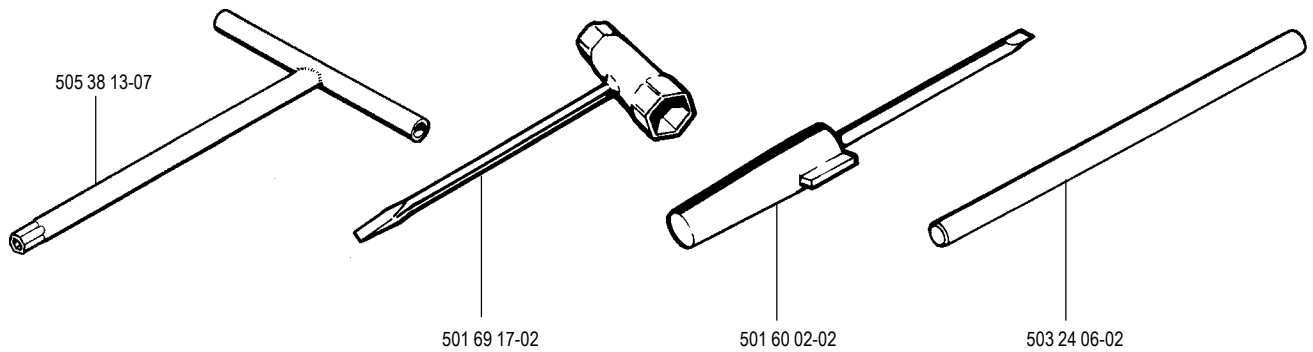

No.	Pos.	Description	No.	Pos.	Description	No.	Pos.	Description
501 22 03-01	M	Plug	505 26 58-15	B	Holder	506 03 62-04	A	Spacer
501 22 04-01	M	Ball	505 26 59-03	B	Ring	506 03 88-01	H	Warning label
501 22 08-01	M	Gasket, metering side	505 26 72-90	B,0	Hub	506 03 95-20	A	Bushing
501 22 09-01	M	Metering diaphragm	505 26 76-73	E	Spacer	506 03 95-22	A	Bushing
501 22 12-01	M	Fuel pump diaphragm	505 26 78-79	A	Tube	506 03 95-25	A	Bushing
501 22 13-01	M	Gasket, pump side	505 26 79-14	J,0	Guide	506 05 68-02	D	Label
501 22 15-01	M	Screw	505 26 91-07	L	Housing	506 05 68-03	D	Label
501 22 17-01	M	Spring	505 26 91-60	J	Plate	506 05 69-01	B	Clutch cover
501 22 20-01	M	Lever	505 26 91-79	K	Starter pawl	506 05 71-03	A	V-belt protector
501 22 23-01	M	Needle	505 26 92-76	D	Mounting bracket	506 05 72-01	L	Fan casing
501 22 24-01	M	Filter	505 26 94-21	E	Throttle rod	506 05 73-01	L	Starter assembly
501 22 25-01	M	Spring	505 26 94-43	E	Choke rod	506 07 01-03	A	Housing
501 26 85-01	M	Needle L	505 27 08-20	E	Shim	506 07 03-02	H	Clutch drum
501 26 89-01	M	Needle H	505 27 20-87	D	Seal, "old"	506 07 03-03	H	Clutch drum
501 42 71-01	M	Bushing	505 27 57-00	B	Seal ring (large)	506 07 03-04	H	Clutch drum
501 48 50-01	M	Gasket	505 27 57-15	J	Seal ring (small)	506 07 05-02	B	V-belt
501 48 52-01	M	Screw	505 27 75-16	K	Insulating cap	506 07 06-01	A	Mounting plate
501 48 54-02	K	Spark plug connecting kit	505 27 75-66	K	Bearing housing	506 07 07-01	A	Flange, support
501 50 24-01	M	Governor	505 27 91-03	E	Throttle control	506 07 08-01	A	Spacer
501 60 02-02	N	Screwdriver	505 27 91-04	E	Throttle catch	506 07 09-01	A	Washer
501 60 68-01	J	Clamp	505 27 91-89	D	Insulating flange	506 07 11-13	J	Hose
501 69 17-02	N	Combi tool	505 27 91-97	L	Plate	506 07 13-01	J,0	Spring
501 76 83-04	J	Hose	505 27 95-07	E	Absorber	506 07 14-02	L	Starter pulley
501 76 83-26	J	Hose, 245 mm	505 27 95-11	E	Absorber	506 07 15-01	J	Crankcase
501 82 18-01	M	Retaining ring	505 27 95-17	E	Absorber	506 07 18-02	A	Pulley
501 82 19-01	M	Cover	505 27 99-35	J	Gasket set	506 07 40-02	D	Air filter
502 01 22-01	M	Choke flap	505 29 41-12	B	Spring	506 07 45-01	E	Handle, front
503 12 81-02	L	Starter handle	505 29 51-10	L	Recoil spring	506 07 46-01	E	Handle, front
503 15 59-02	E	Bracket right	505 29 56-13	K	Spring	506 07 61-01	D	Filter holder
503 16 03-02	L	Decal	505 29 56-14	E	Spring	506 07 63-01	D	Gasket set
503 17 99-01	E	Stop button	505 29 79-17	L	Lock spring	506 07 64-01	D	Filter set
503 20 00-01	A,E,J,K	Screw M6SF 5x20	505 30 23-31	G,0	Needle bearing	506 07 65-02	D	Seal
503 20 00-03	D,E,F	Screw M6SF 5x12	505 30 24-15	B	Support bushing	506 09 60-01	J	Filter
503 20 00-05	C,L,0	Screw M6SF 5x25	505 30 32-12	B	Clutch shoe	506 09 61-01	J,0	Gasket
503 20 00-07	J,0	Screw M6SF 5x40	505 30 32-50	B	Clutch	506 09 62-01	C,0	Gasket
503 20 00-08	A,B,E	Screw M6SF 5x30	505 30 51-20	L	Starter rope	506 09 63-01	D	Gasket
503 20 00-09	J,0	Screw M6SF 5x45	505 31 04-39	D	Intake pipe	506 09 64-01	D	Gasket
503 20 00-10	E	Screw M6SF 5x55	505 31 22-26	J	Tank cap	506 09 65-01	C	Gasket
503 20 00-12	D	Screw M6SF 5x70	505 31 55-30	D	Air filter	506 09 76-01	D	Seal
503 20 00-17	F	Screw M6SF 5x80	505 31 55-67	D	Pre-filter	506 09 77-01	D	Seal
503 20 00-21	E,K	Screw M6SF 5x18	505 31 55-70	D	Filter	506 09 78-01	D	Cylinder cover
503 20 00-45	A	Screw	505 31 64-58	M	Pressure spring	506 13 82-01	H	Guard
503 20 31-01	L	Screw LKCS 3x10	505 31 64-95	M	Sealing ring	506 13 83-01	H	Guard
503 21 28-10	E	Screw	505 31 66-02	M	Choke shaft	506 13 95-01	A	Washer
503 22 00-01	A	Nut M6MF M8	505 31 66-05	M	Spring	506 13 96-01	A	Screw
503 22 21-01"	K	Lock nut M8x1	505 31 66-19	M	Throttle shaft	506 14 01-01	E	Choke button
503 22 65-04	E,J	Nut	505 31 66-21	D	Carburetor	506 14 02-01	E	Handle, right
503 23 00-05	H	Washer 6.5x11	505 32 56-21	K	Flywheel	506 14 12-01	G,0	Crankshaft
503 23 00-11	E	Washer 5.3x12	505 34 07-54	E	Handle, left half	506 14 32-02	A	Catch
503 23 00-32	K	Washer 5.3x15	505 34 08-12	C	Piston cpl, 52 mm K850	506 14 40-01	D	Wing nut
503 23 01-01	K	Washer 8.4x16	505 34 09-27	K	Bracket	506 14 72-04	E	Plug
503 23 01-02	M	Washer 5.25x9	505 34 12-23	D	Rubber cover	506 21 21-01	H	Washer
503 23 01-04	A	Washer 15x21	505 34 12-65	C,0	Cylinder cpl.	506 21 23-01	D	Gasket
503 23 51-08	K,0	Spark plug RCJ7Y	505 34 12-67	C,0	Piston cpl, 56 mm	506 21 91-01	J	Grommet
503 24 06-02	N	Pin 3.6x120	505 35 02-50	E	Handle	506 22 34-01	J	Tank
503 25 00-02	G,J,0	Ball bearing 6203C3QE6	505 35 04-15	F	Silencer	506 22 88-01	D	Screw driver guide
503 25 22-01	A	Ball bearing	505 38 13-07	N	Socket wrench	506 23 61-01	J	Tank ventilation
503 28 90-24	C,0	Piston ring	505 39 75-73	D	Label start instructions	506 25 88-01	M	Gasket kit
503 40 13-02	E	Bracket left	505 39 75-77	D	Decal	506 26 00-02	H	Guard
503 40 17-01	E	Contact spring	506 01 31-01	A	Bolt	506 26 75-01	A	Plastic seal
503 40 18-01	E	Holder	506 02 72-07	K	Ignition cpl	506 27 63-01	M	Repair kit
503 41 18-02	K	Cable	506 02 84-01	A	Washer	720 13 07-10	J,0	Pin
503 47 83-01	M	Throttle flap	506 02 85-72	A	Shaft	721 42 58-20	E	Spring pin 4x24
503 48 63-01	M	Cover screw	506 02 87-01	A	Washer	725 52 95-55	K	Screw MC6S 4x20
503 49 08-01	D	Gasket	506 02 88-30	A	Bushing	725 53 33-55	D	Screw MC6S 5x25
503 53 40-01	M	Nipple	506 02 95-01	H,L	Hose	729 22 23-01	L	Screw CSK B4x8
503 57 86-01	M	Ball	506 02 95-02	H	Hose	731 23 10-01	L	Nut M6M M3
503 57 87-01	M	Idle adjustment screw	506 02 95-03	H	Hose	735 11 36-50	K	Spring washer 4.3x8
503 65 27-01	M	Screw	506 02 96-01	H	Spring	735 11 46-50	D	Spring washer 5.3x10
503 77 98-01	M	Valve	506 02 98-01	H	Control knob	735 31 09-20	H	E-ring 5
503 84 50-01	K	Cable	506 02 98-02	H	Control knob	735 31 12-20	J	Retaining ring
504 35 72-01	J	Fuel filter	506 02 98-04	H	Lever	735 58 18-00	E	Lock washer 2.4
505 20 29-51	J	Pushrod	506 03 45-01	A	Washer	735 88 06-00	G	Woodruff key
505 20 29-52	J	Rod	506 03 62-01	A	Spacer	737 43 12-00	G,0	Retaining ring
505 26 21-72	A	Eccentric	506 03 62-02	A	Spacer	740 48 18-04	J	O-ring



Assembly of Rear Handle K650/K700 and K1200

When the handle is apart, follow these steps for re-assembly.

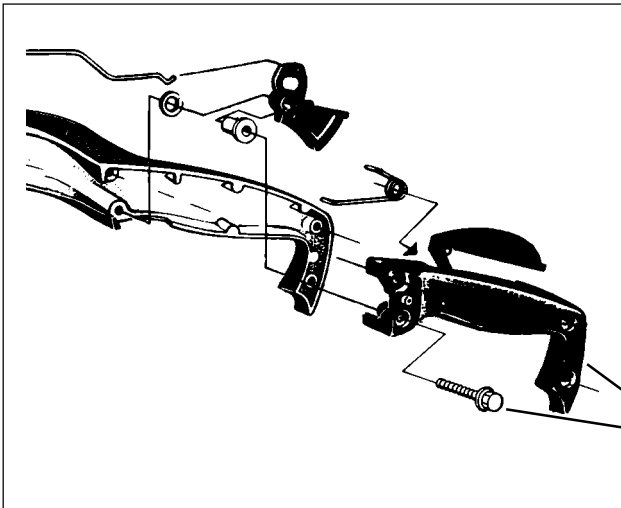

1. Insert the longer handle screw into this hole in the left handle half . This screw acts as a pivot for the trigger.

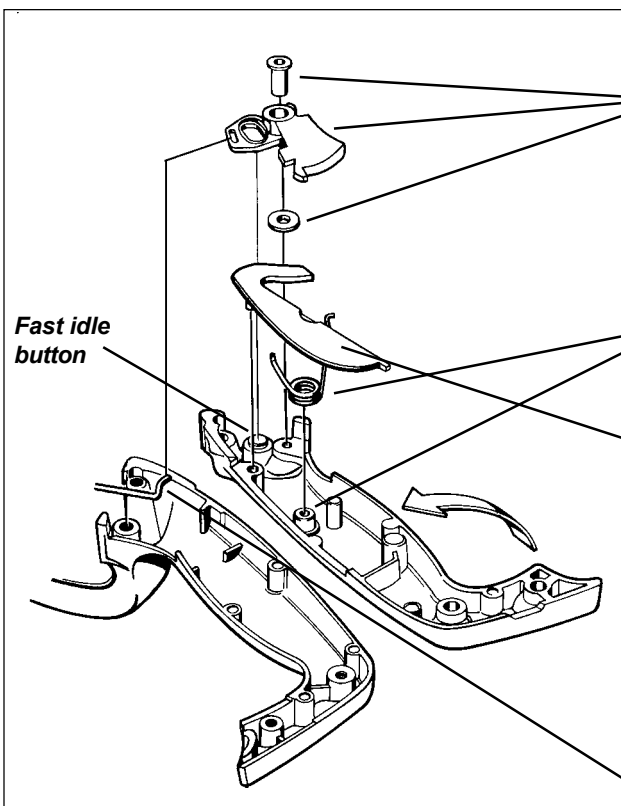

2. Install the **washer**, **trigger** and **sleeve** onto the screw.

3. Install the **spring** on the post identified in the drawing and insert the hook on the spring into matching hole on the trigger.

4. Install the **throttle lockout**.

5. Set the **fast idle button** by pressing on the throttle lockout and the trigger simultaneously. The fast idle button effectively holds the parts in place.

6. Install the handle assembly onto throttle linkage.