

PARTNER

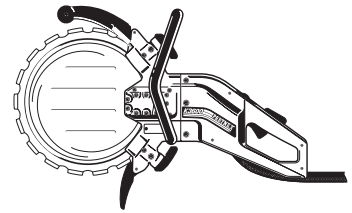

IPL, K3600, 1999-06, 106 25 76-61

K3600

Reservdelar

Spare parts

Ersatzteile

Pieces de rechange

Piezas de repuesto

Ricambi

***Peças
sobresselente***

106 25 76-61

PARTNER[®]

A

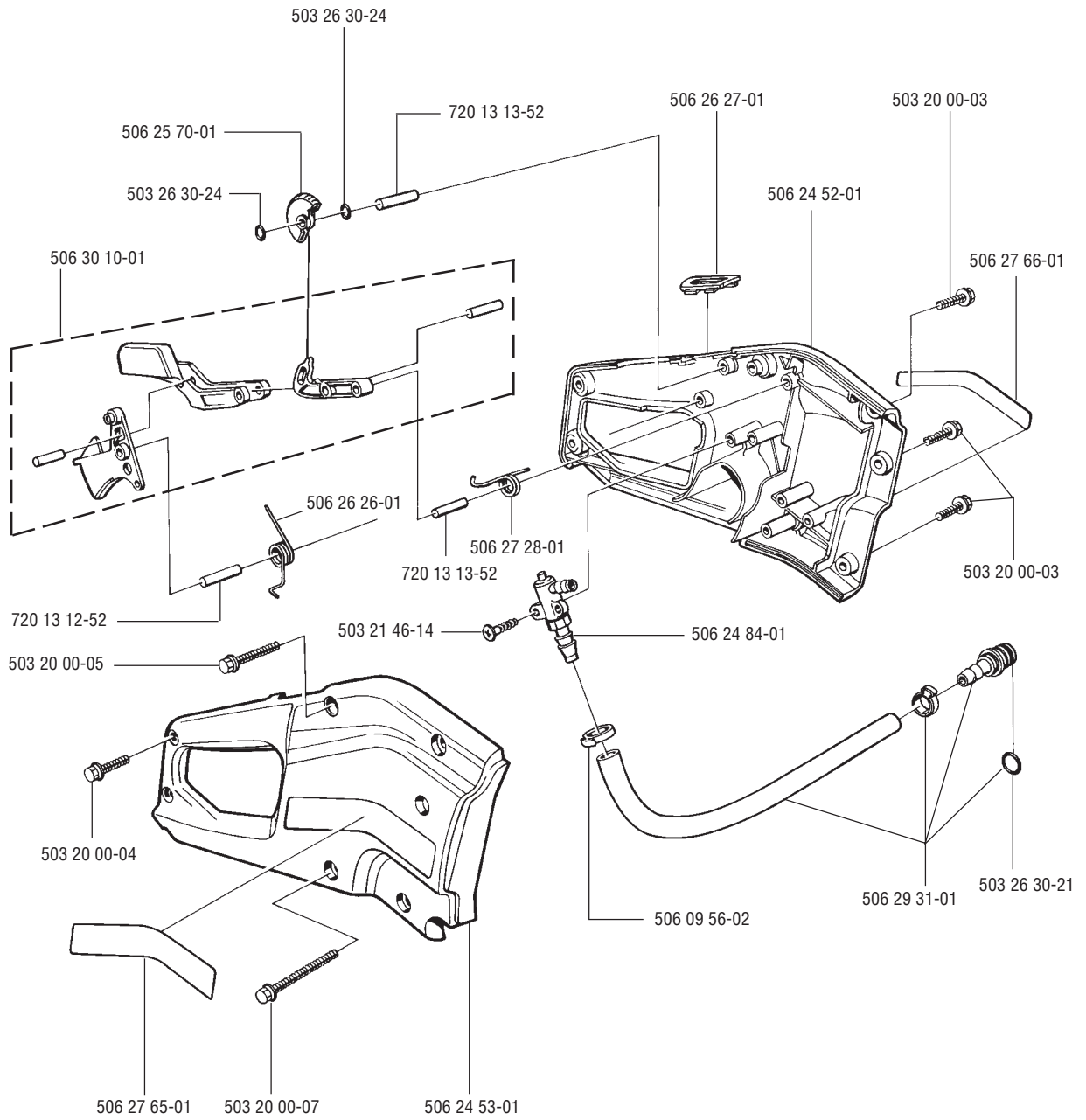

B compl. 506 28 51-01

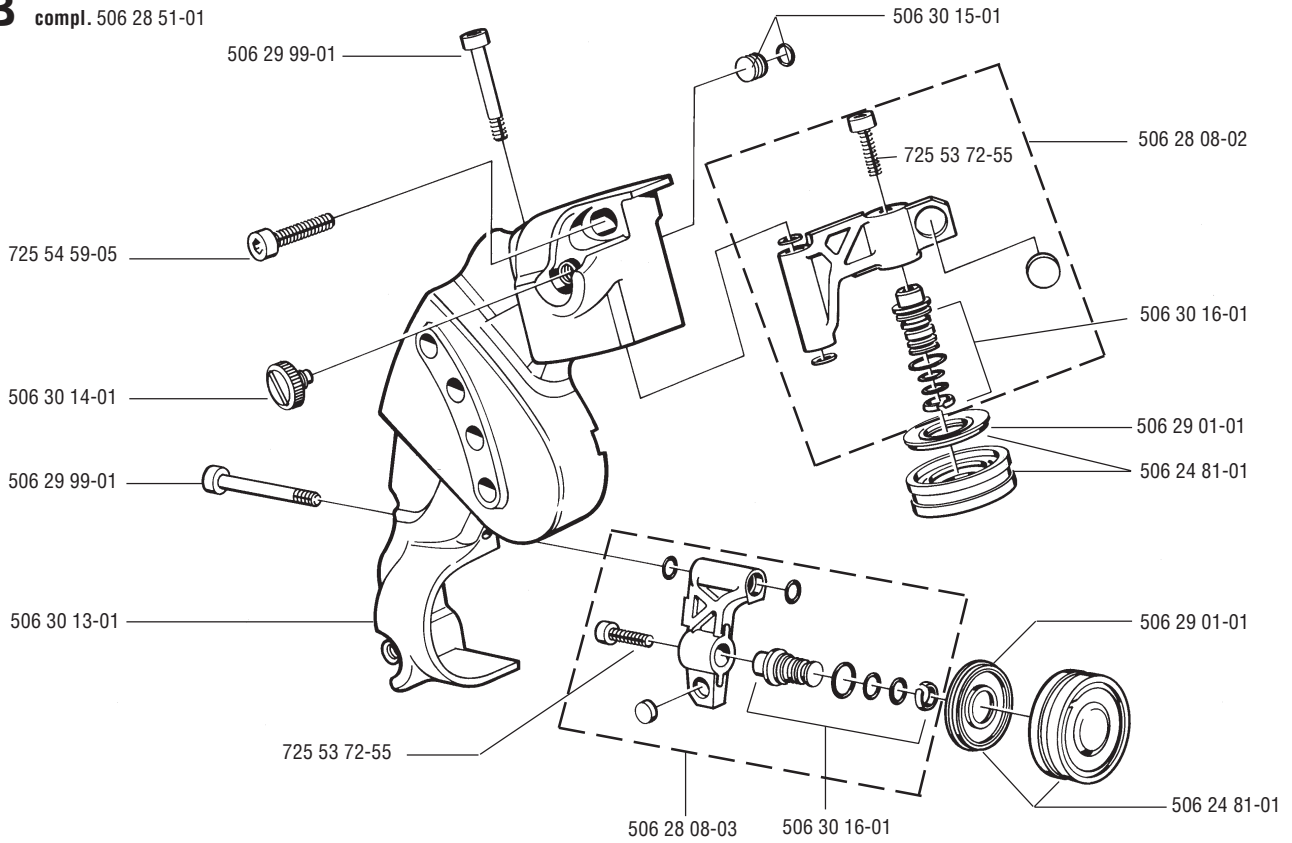

C * compl. 506 30 06-01

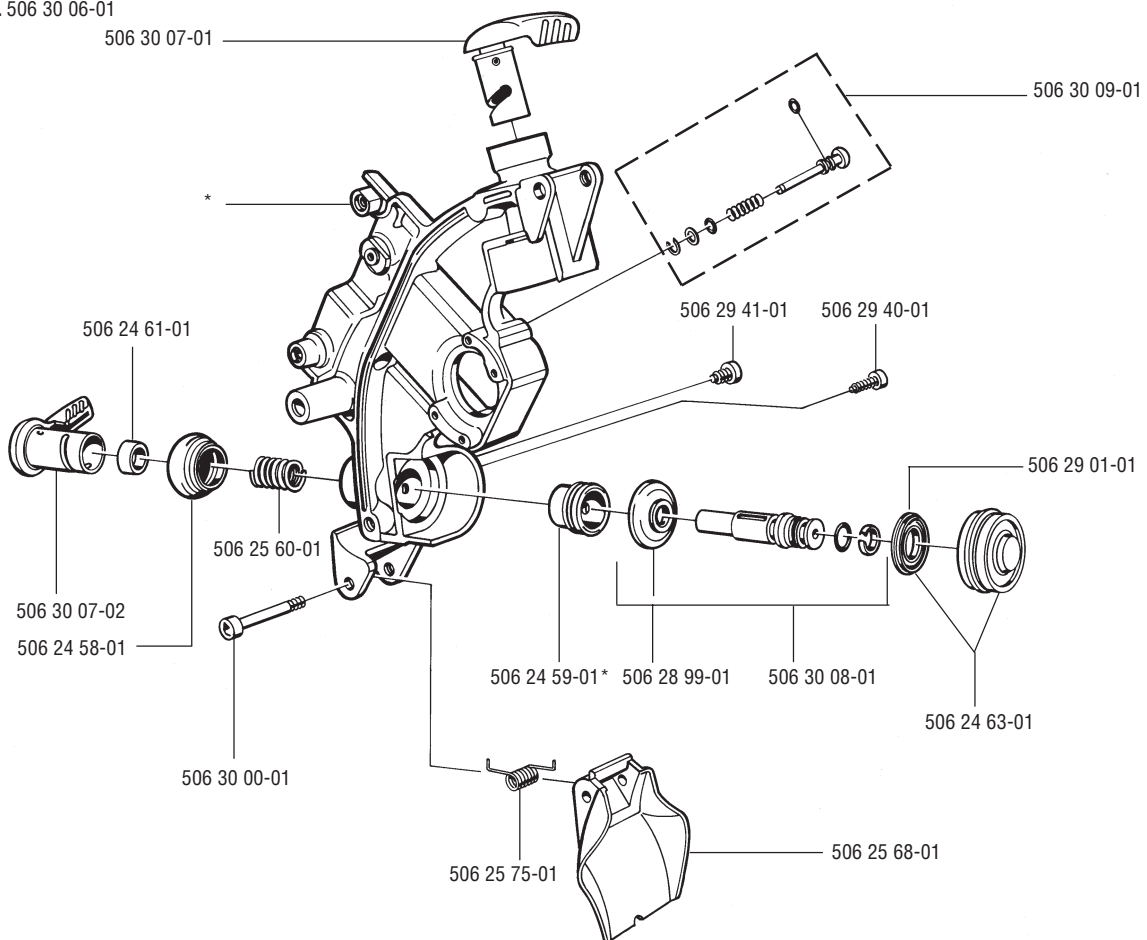

D Hydr. motor compl. 506 19 87-01

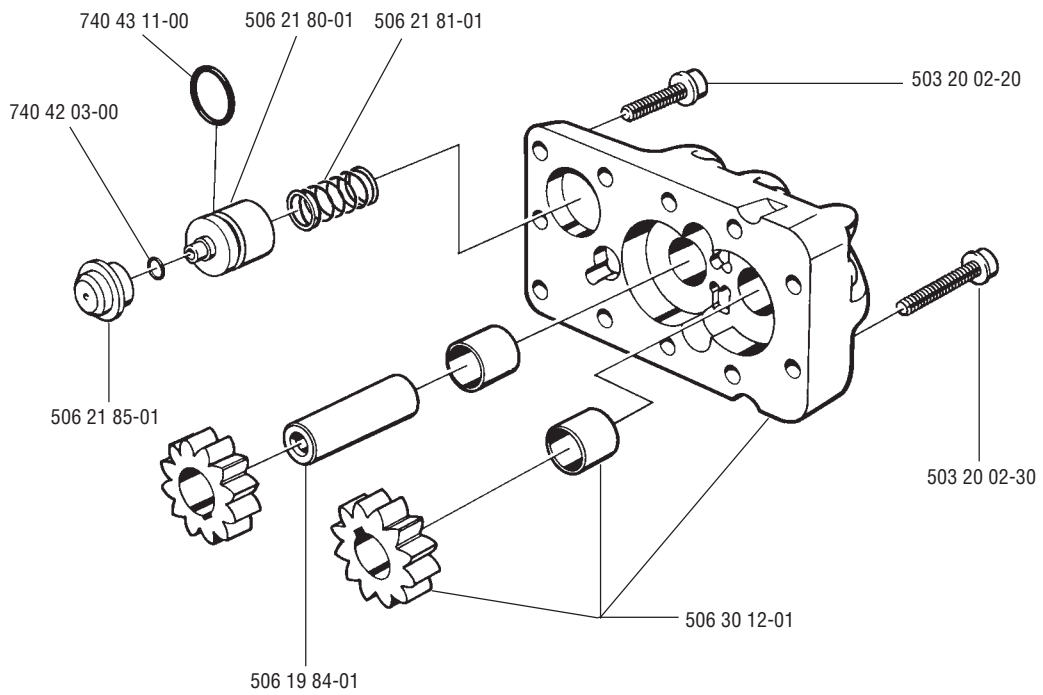

E Hydr. motor compl. 506 19 87-01

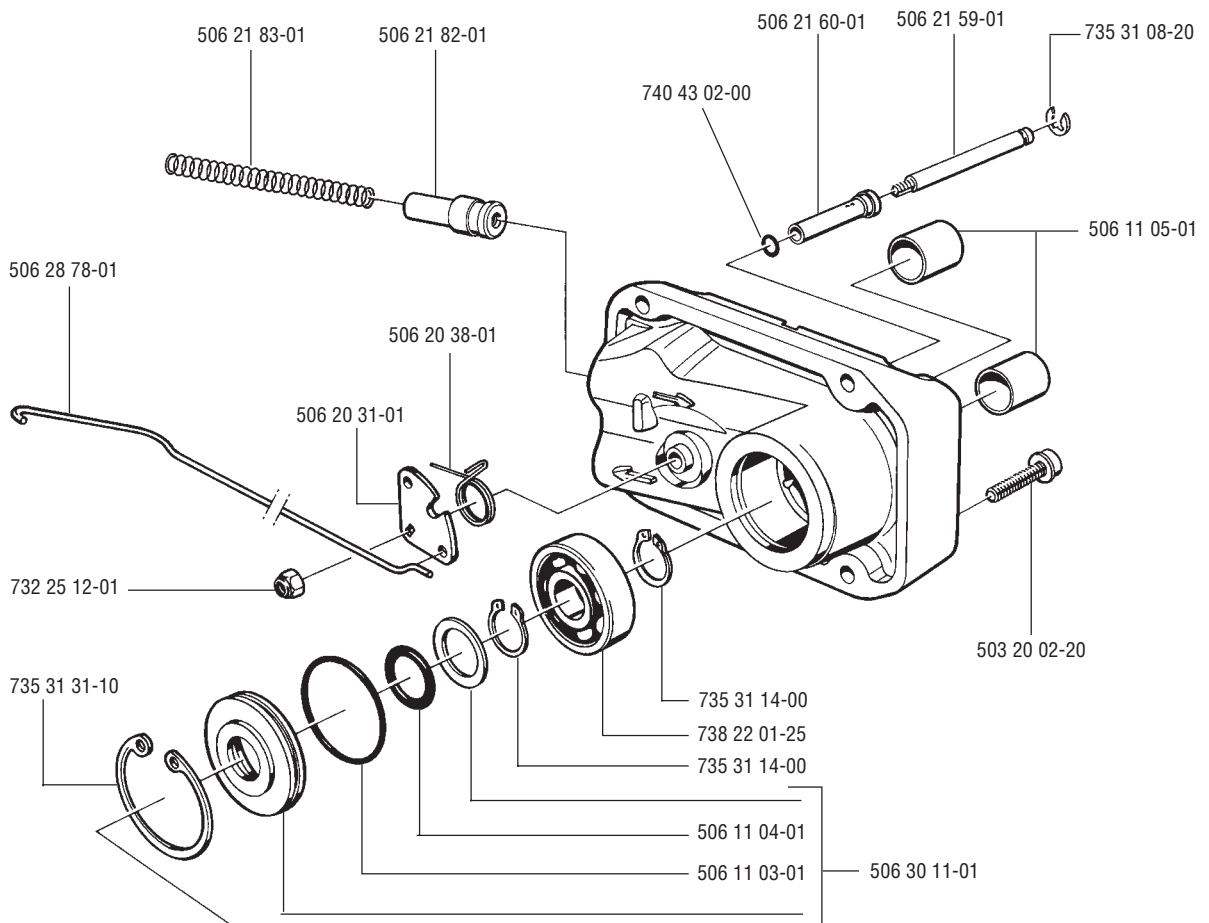

F Hydr. motor compl. 506 19 87-01

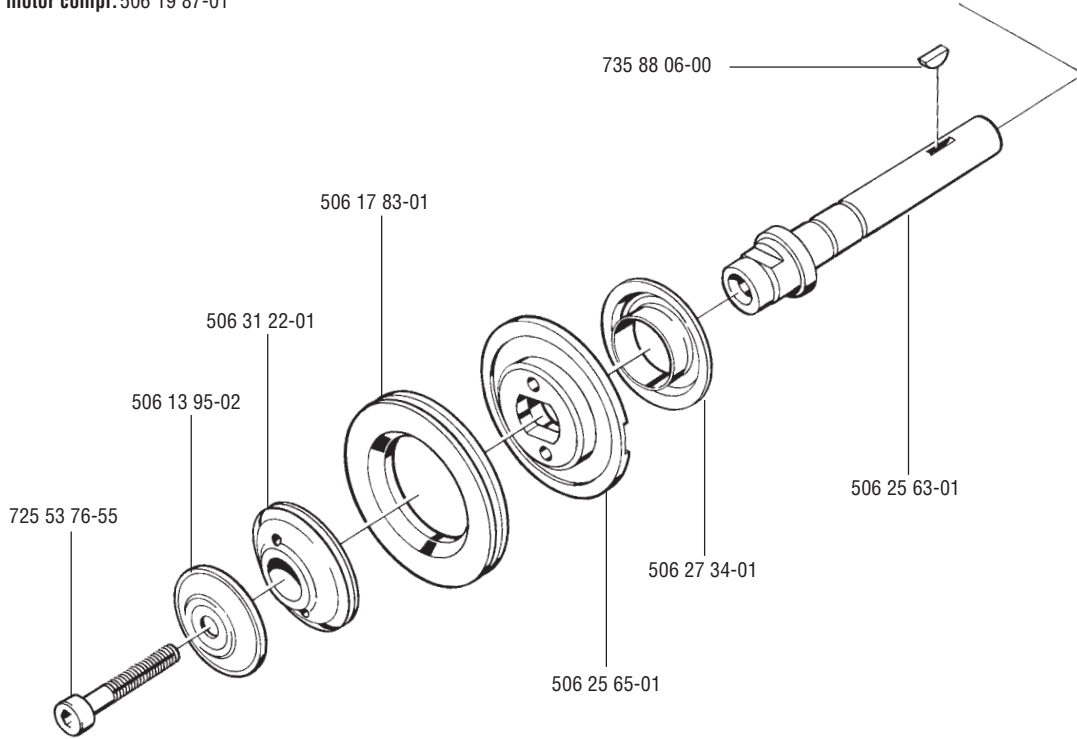

G

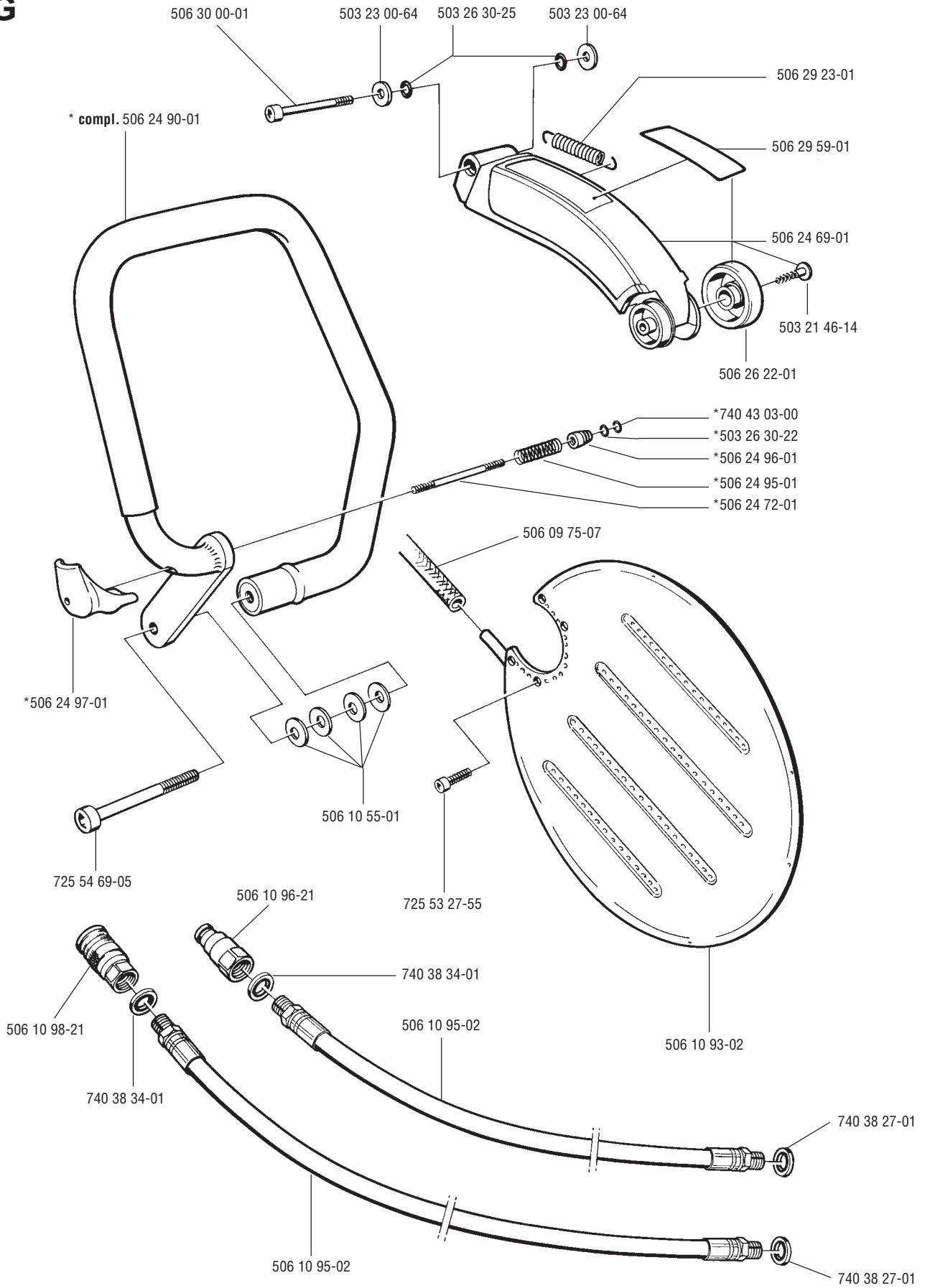

No.	Pos.	Denomination	No.	Pos.	Denomination	No.	Pos.	Denomination
503 20 00-03	A	Screw M6SF 5x12	506 29 40-01	C	Stop screw			
503 20 00-04	A	Screw M6SF 5x16	506 29 41-01	C	Stop screw			
503 20 00-05	A	Screw M6SF 5x25	506 29 59-01	G	Warning decal			
503 20 00-07	A	Screw M6SF 5x40	506 29 99-01	B	Screw, M6x54			
503 20 02-20	D, E	Screw	506 30 00-01	C, G	Screw, M6x45			
503 20 02-30	D	Screw	506 30 06-01	C	Chassis			
503 21 46-14	A, G	Screw	506 30 07-01	C	Handle, upper			
503 23 00-64	G	Washer	506 30 07-02	C	Handle, lower			
503 26 30-21	A	O-ring	506 30 08-01	C	Shaft, cpl			
503 26 30-22	G	O-ring	506 30 09-01	C	Locking device			
503 26 30-24	A	O-ring	506 30 10-01	A	Trigger, kit			
503 26 30-25	G	O-ring	506 30 11-01	E	Seal, cpl			
506 09 56-02	A	Clamp	506 30 12-01	D	Cover motor, cpl			
506 09 75-07	G	Hose	506 30 13-01	B	Support roller cover			
506 10 55-01	G	Spring	506 30 14-01	B	Adjusting screw			
506 10 93-02	G	Stabilizer blade	506 30 15-01	B	Plug with O-ring			
506 10 95-02	G	Hose	506 30 16-01	B	Shaft, cpl, support			
506 10 96-21	G	Coupler 3/8" (fem) FF, BSP	506 31 22-01	F	Flange washer			
506 10 98-21	G	Coupler 3/8" (male) FF, BSP	720 13 12-52	A	Pin, 5x25			
506 11 03-01	E	O-ring	720 13 13-52	A	Pin, 5x28			
506 11 04-01	E	O-ring	725 53 27-55	G	Screw, MC6 5x12			
506 11 05-01	E	Bearing	725 53 72-55	B	Screw, 6x25			
506 13 95-02	F	Washer	725 53 76-55	F	Screw, 6x35			
506 17 83-01	F	Drive disc	725 54 59-05	B	Screw, 8x40			
506 19 84-01	D	Shaft	725 54 69-05	G	Screw, 8x90			
506 19 87-01	D,E,F	Hydr. motor compl	732 25 12-01	E	Nut, M4			
506 20 31-01	E	Lever	735 31 08-20	E	E-ring 4			
506 20 38-01	E	Spring	735 31 14-00	E	Seeger clip			
506 21 59-01	E	Valve spindle	735 31 31-10	E	Retaining ring			
506 21 60-01	E	Sleeve	735 88 06-00	F	Woodruff key			
506 21 80-01	D	Valve	738 22 01-25	E	Ball bearing 6201-C3			
506 21 81-01	D	Spring	740 38 27-01	G	Washer, 1/4"			
506 21 82-01	E	Piston	740 38 34-01	G	Washer, 3/8"			
506 21 83-01	E	Spring	740 42 03-00	D	O-ring			
506 21 85-01	D	Valve seat	740 43 02-00	E	O-ring			
506 24 52-01	A	Handle, left	740 43 03-00	G	O-ring			
506 24 53-01	A	Handle, right	740 43 11-00	D	O-ring			
506 24 58-01	C	Bellow						
506 24 59-01	C	Sleeve						
506 24 61-01	C	Bushing						
506 24 63-01	C	Guide roller, cpl						
506 24 69-01	G	Blade guard, cpl						
506 24 72-01	G	Screw						
506 24 81-01	B	Support roller, cpl						
506 24 84-01	A	Valve, water, cpl						
506 24 90-01	G	Handle, cpl						
506 24 95-01	G	Spring						
506 24 96-01	G	Locking pin						
506 24 97-01	G	Locking handle						
506 25 60-01	C	Spring						
506 25 63-01	F	Shaft						
506 25 65-01	F	Drive disc support						
506 25 68-01	C	Splash guard						
506 25 70-01	A	Control, water						
506 25 75-01	C	Spring						
506 26 22-01	G	Roller						
506 26 26-01	A	Spring						
506 26 27-01	A	Window						
506 27 28-01	A	Spring						
506 27 34-01	F	Sealing						
506 27 65-01	A	Decal, right						
506 27 66-01	A	Decal, left						
506 28 08-02	B	Holder, upper						
506 28 08-03	B	Holder, lower						
506 28 51-01	B	Support roller cover, cpl						
506 28 78-01	E	Rod						
506 28 99-01	C	Bellow						
506 29 01-01	B, C	Sealing						
506 29 23-01	G	Spring						
506 29 31-01	A	Water hose, cpl						

