

PARTNER

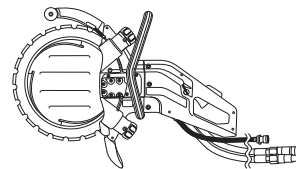

IPL, K3600 MkII, 2005-04, 544 00 59-02

K3600 MkII

Reservdelar

Spare parts

Ersatzteile

Pieces de rechange

Piezas de repuesto

Ricambi

***Peças
sobresselente***

544 00 59-02

PARTNER®

No.	Pos.	Description	No.	Pos.	Description
503 20 00-03	A	SCREW	506 38 23-01	C	ENGAGEMENT ROLLER CPL
503 20 00-04	A	SCREW	506 38 23-02	C	ENGAGEMENT ROLLER CPL
503 20 00-05	A	SCREW	506 38 97-01	C	PIN
503 20 00-07	A	SCREW	738 88 10-01	C	GREASE NIPPLE
503 26 30-21	A	O-RING	740 48 20-12	C	O-RING
506 09 56-02	A	CLAMP	740 48 25-02	C	O-RING
506 09 56-03	A	CLAMP	503 20 02-20	D	SCREW
506 20 34-02	A	THROTTLE TRIGGER	503 20 07-30	D	SCREW
506 24 52-02	A	HANDLE	503 24 07-01	D	PIN
506 24 53-02	A	HANDLE	503 26 30-28	D	O-RING
506 26 26-01	A	SPRING	506 11 03-01	D	O-RING
506 27 21-01	A	THROTTLE LOCK	506 11 05-01	D	BUSHING
506 29 31-01	A	HOSE	506 13 95-12	D	WASHER
506 29 88-01	A	SCREEN	506 17 83-01	D	RING
506 31 63-01	A	PLATE	506 19 87-03	D	HYDRAULIC MOTOR CPL
506 34 94-01	A	WATER TAP	506 20 31-01	D	LEVER
506 35 54-01	A	WINDOW	506 20 38-01	D	SPRING
506 36 49-01	A	DECAL	506 21 59-01	D	VALVE SPINDLE
506 36 50-01	A	DECAL	506 21 60-01	D	SLEEVE
506 37 76-01	A	THROTTLE TRIGGER CPL	506 21 80-01	D	VALVE
720 12 71-52	A	PIN	506 21 81-01	D	SPRING
720 13 13-06	A	PIN	506 21 82-01	D	PISTON
720 13 16-06	A	PIN	506 21 83-01	D	SPRING
503 21 46-01	AE	SCREW	506 21 85-01	D	VALVE SEAT
503 20 54-35	B	SCREW	506 23 35-01	D	HOUSING
503 22 00-01	B	NUT	506 25 65-02	D	WASHER
503 23 04-03	B	WASHER	506 27 34-01	D	SEALING
503 26 30-08	B	O-RING	506 30 11-14	D	SEALING KIT
503 26 30-26	B	O-RING	506 30 12-01	D	COVER W PINION SET
506 28 03-72	B	COVER	506 31 22-01	D	CARRIER CPL
506 30 14-02	B	ADJUSTING SCREW	506 32 00-01	D	SHAFT
506 30 29-02	B	SHAFT	506 32 08-02	D	WHEEL CPL
506 30 33-02	B	SPACER SLEEVE	506 34 67-04	D	SHAFT
506 31 68-02	B	SPACER SLEEVE	506 35 95-01	D	ROD
506 32 17-01	B	SEALING	725 53 76-55	D	SCREW
506 33 08-01	B	BUSHING	732 25 12-01	D	NUT M4
506 33 49-01	B	PIPE, SPACER	735 31 08-20	D	E-RING
506 34 63-01	B	WASHER	735 31 14-00	D	SEEGER CLIP
506 34 64-01	B	SCREW	735 31 31-10	D	RETAINING RING
506 35 18-06	B	ARM ROLLER CPL	735 88 06-00	D	WOODRUFF KEY
506 35 21-02	B	SUPPORT ROLLER	738 22 01-25	D	BALL BEARING
506 37 63-01	B	SPACER	740 42 03-00	D	O-RING
506 37 64-01	B	BUSHING	740 43 02-00	D	O-RING
506 39 95-01	B	SEALING	740 43 11-00	D	O-RING
725 53 81-56	B	SCREW	503 26 30-22	E	O-RING
740 42 04-00	B	O-RING	503 26 30-25	E	O-RING
503 20 13-18	BC	SCREW	506 09 75-07	E	HOSE
503 20 46-16	BC	SCREW	506 10 55-01	E	SPRING
503 25 24-01	BC	BALL BEARING	506 10 93-02	E	STABILIZER BLADE
503 26 20-01	BC	SEALING RING	506 24 69-02	E	BLADE GUAR CPL
506 30 34-01	BC	CARRIER	506 24 95-01	E	SPRING
506 35 19-01	BC	WEAR PROTECTOR	506 25 68-01	E	SPLASH GUARD
506 37 93-02	BC	SLEEVE	506 25 75-01	E	SPRING
735 31 28-10	BC	RETAINING RING	506 26 22-01	E	ROLLER
506 30 09-01	C	CATCH, KIT	506 29 23-01	E	SPRING
506 30 29-01	C	SHAFT	506 29 59-01	E	WARNING DECAL
506 30 33-01	C	SPACER SLEEVE	506 31 28-01	E	PLATE
506 30 35-01	C	PROTECTOR	506 31 45-01	E	PIPE
506 31 68-01	C	SPACER SLEEVE	506 35 65-01	E	PIN
506 31 69-01	C	DUST PROTECTOR	506 35 72-01	E	HANDLE
506 33 65-01	C	SEALING RING	506 35 73-01	E	GRIP
506 34 39-01	C	SEALING	725 53 27-55	E	SCREW
506 34 76-01	C	SPRING	725 53 79-56	E	SCREW
506 35 20-02	C	ENGAGEMENT ROLLER	725 53 80-06	E	SCREW
506 35 20-03	C	ENGAGEMENT ROLLER	725 54 69-05	E	SCREW
506 36 83-71	C	CHASSIS	734 48 80-01	E	WASHER
506 38 09-01	C	HOLDER	740 43 03-00	E	O-RING
506 38 10-01	C	SLEEVE	506 10 95-02	F	HYDRAULIC HOSE
506 38 11-01	C	COVER	506 10 96-21	F	QUICK COUPLING FEMALE
506 38 22-01	C	KNOB	506 10 98-21	F	QUICK COUPLING MALE

No.	Pos.	Description	No.	Pos.	Description
740 38 27-01	F	WASHER			
740 38 34-01	F	WASHER			
501 19 22-01	G	TOOL BAG			
501 69 17-02	G	COMB.TOOL			
502 21 58-01	G	ALLEN KEY			
503 62 12-01	G	GREASE			
506 35 52-01	G	KEY			
506 36 36-01	G	L-SPANNER			
506 36 38-02	G	TOOL KIT			
506 38 37-02	G	L-KEY			
506 38 49-01	G	GREASE GUN			

A

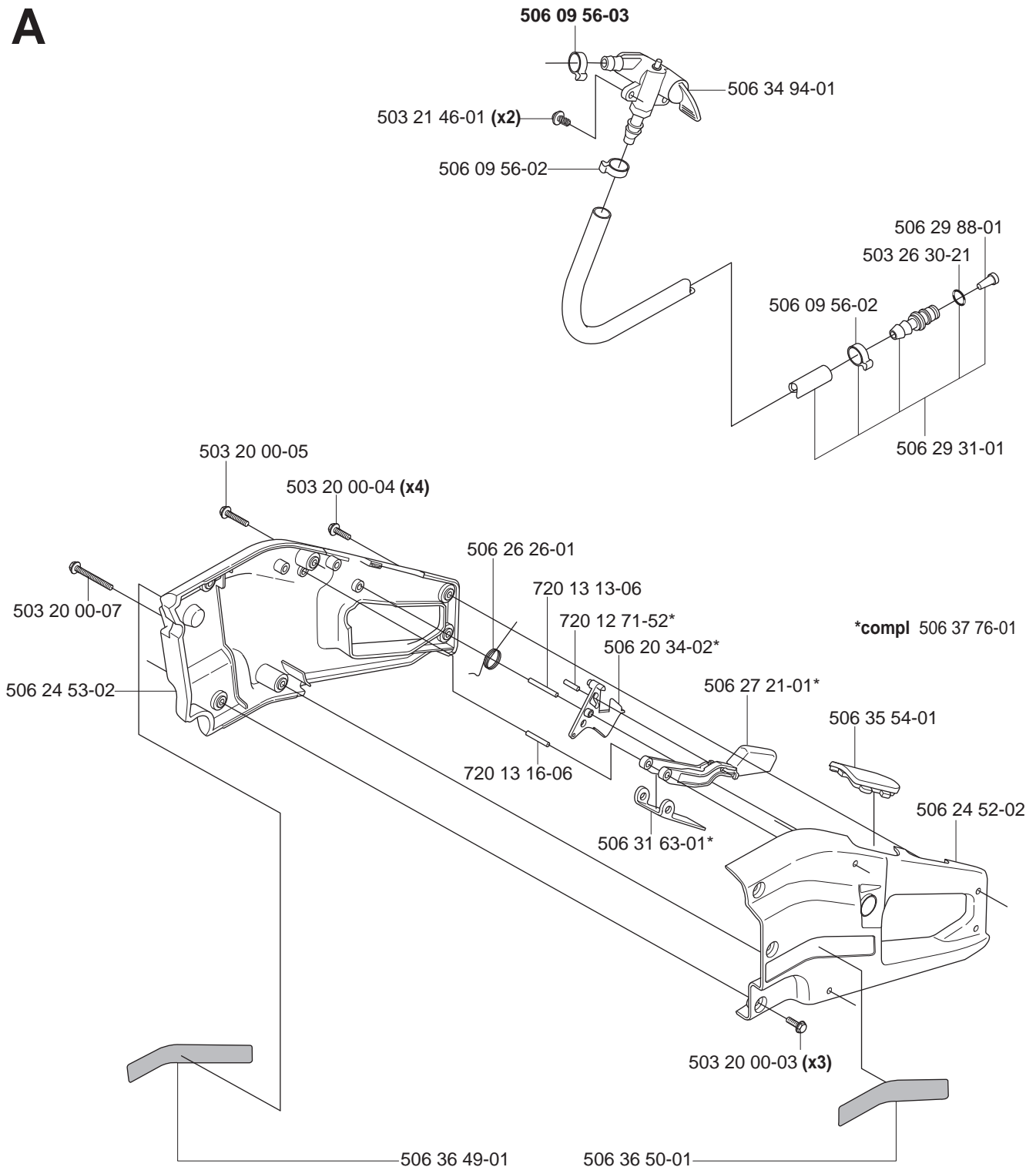

B Arm
*compl 506 35 18-06

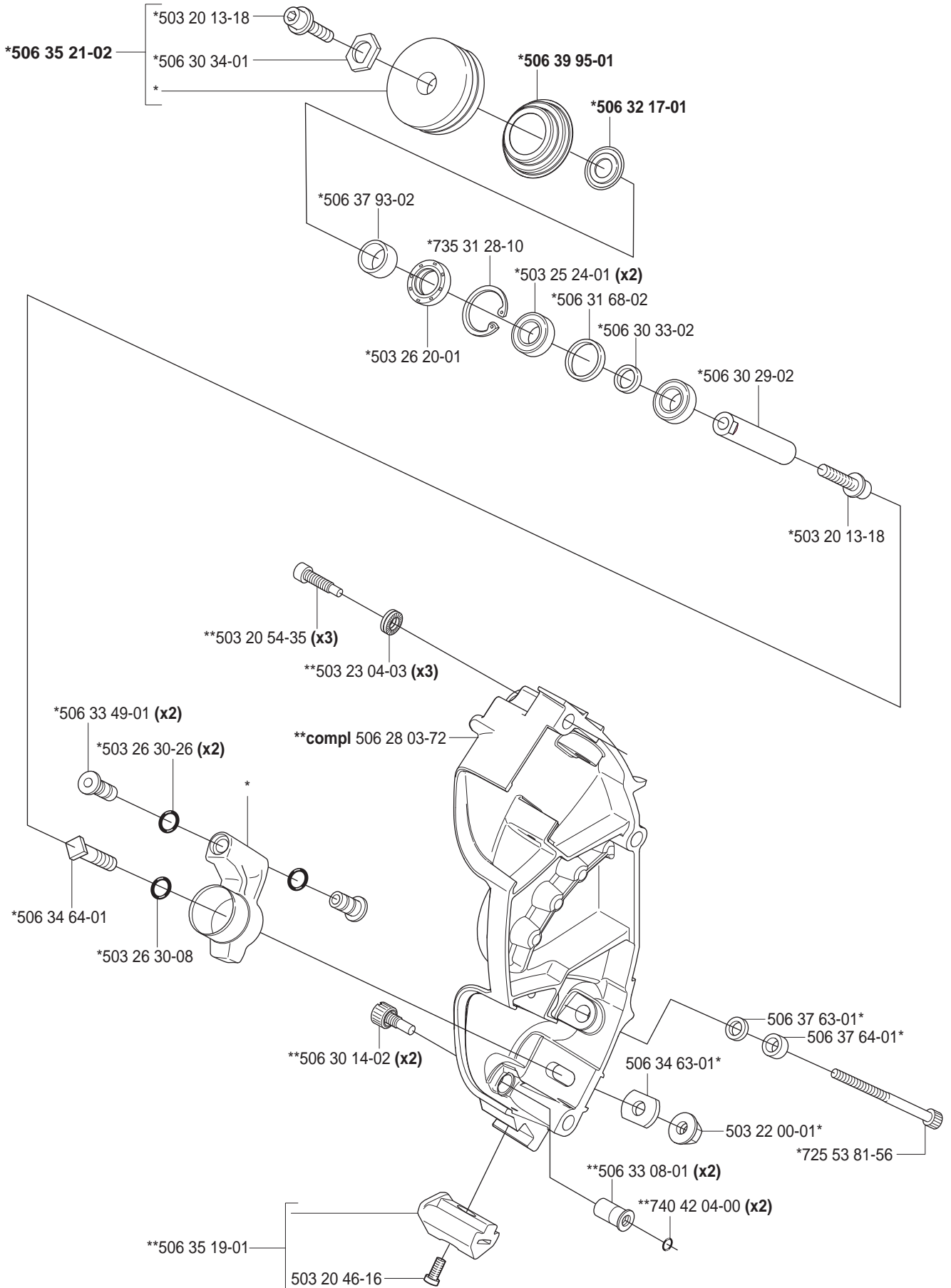

C

*compl 506 38 23-02 (Sweden only)
*compl 506 38 23-01

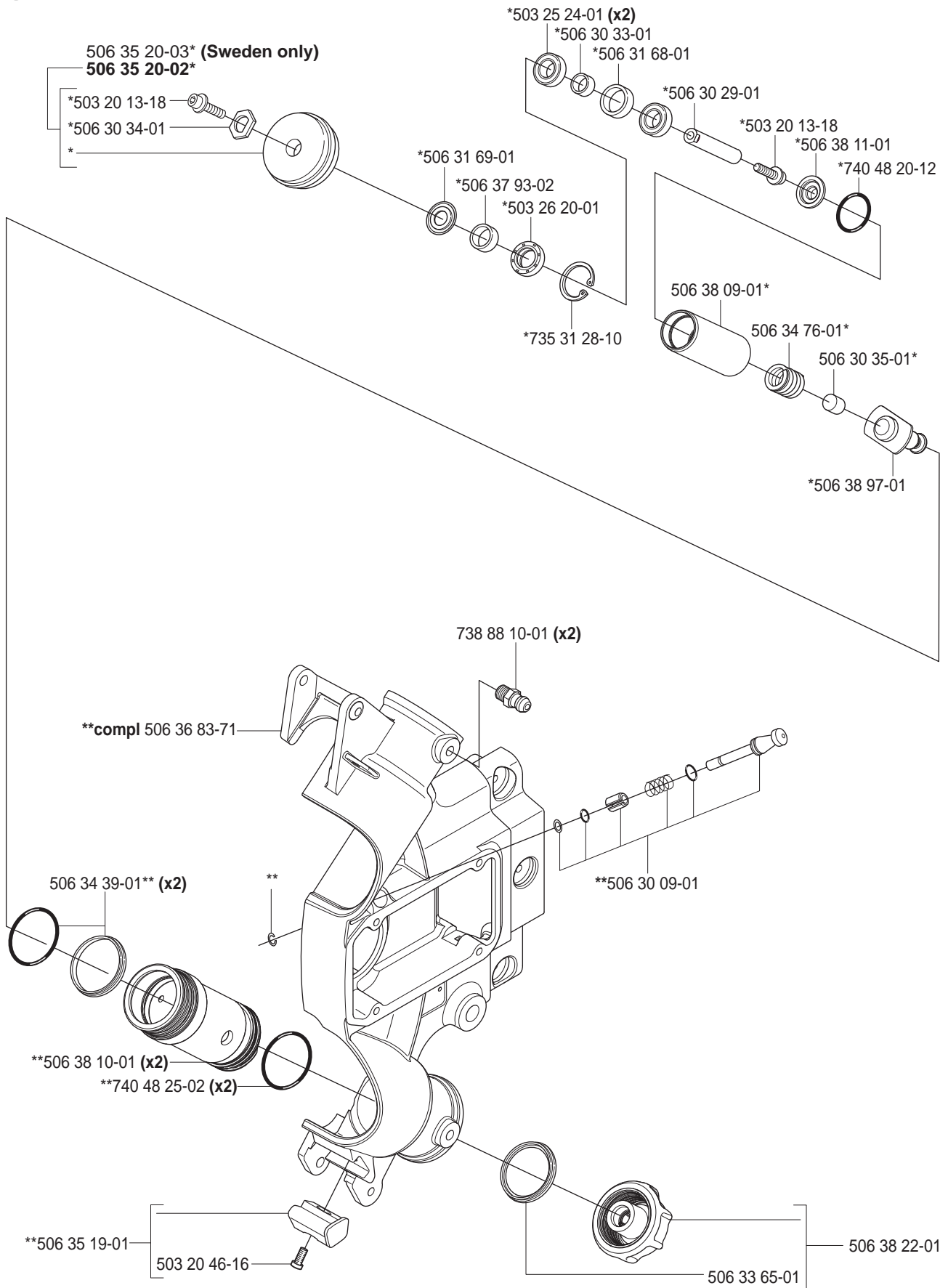

D

*compl 506 32 08-02

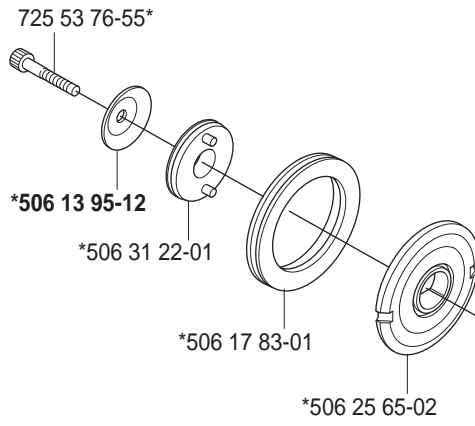

D

Hydr. motor
compl 506 19 87-03

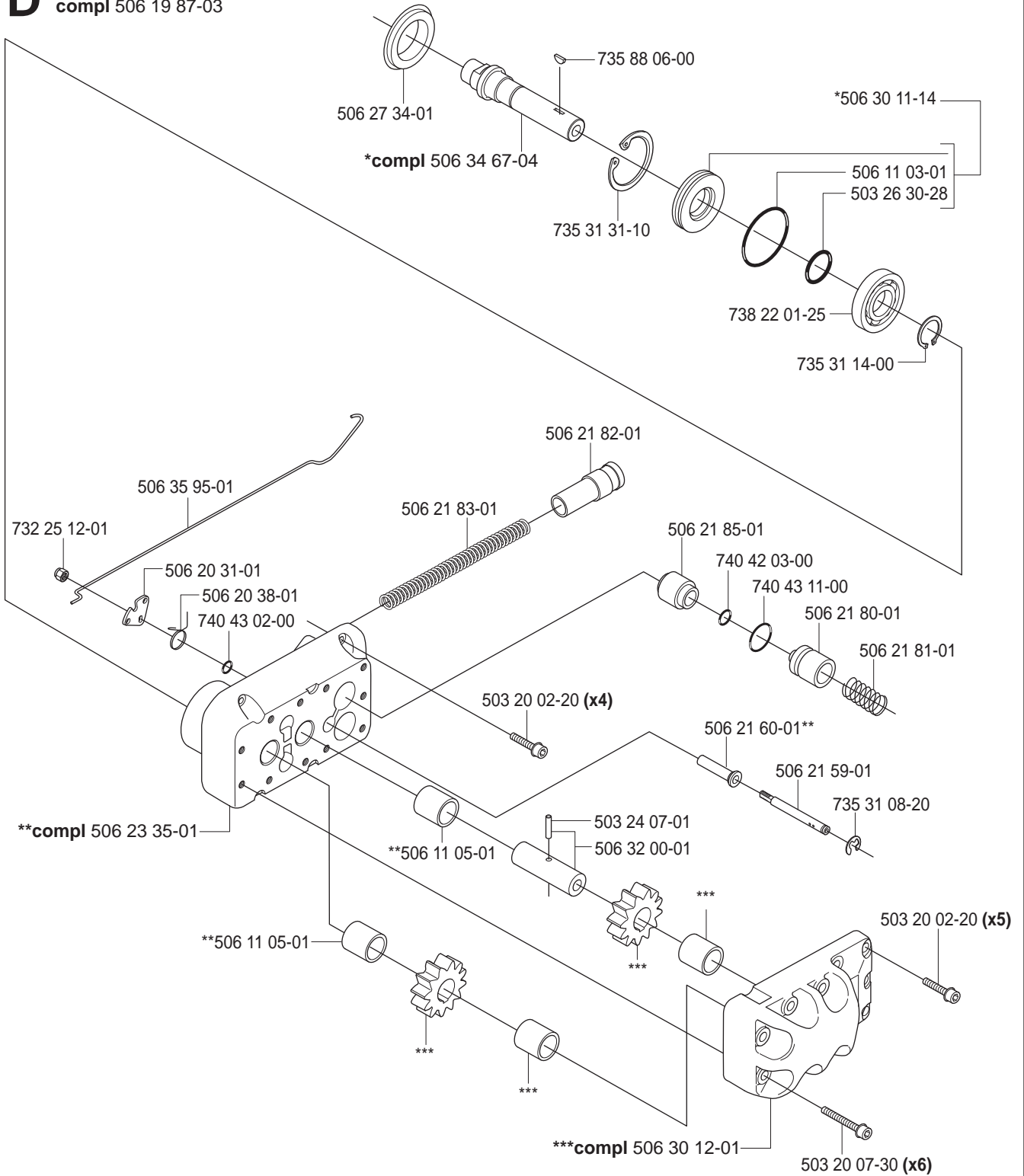

E

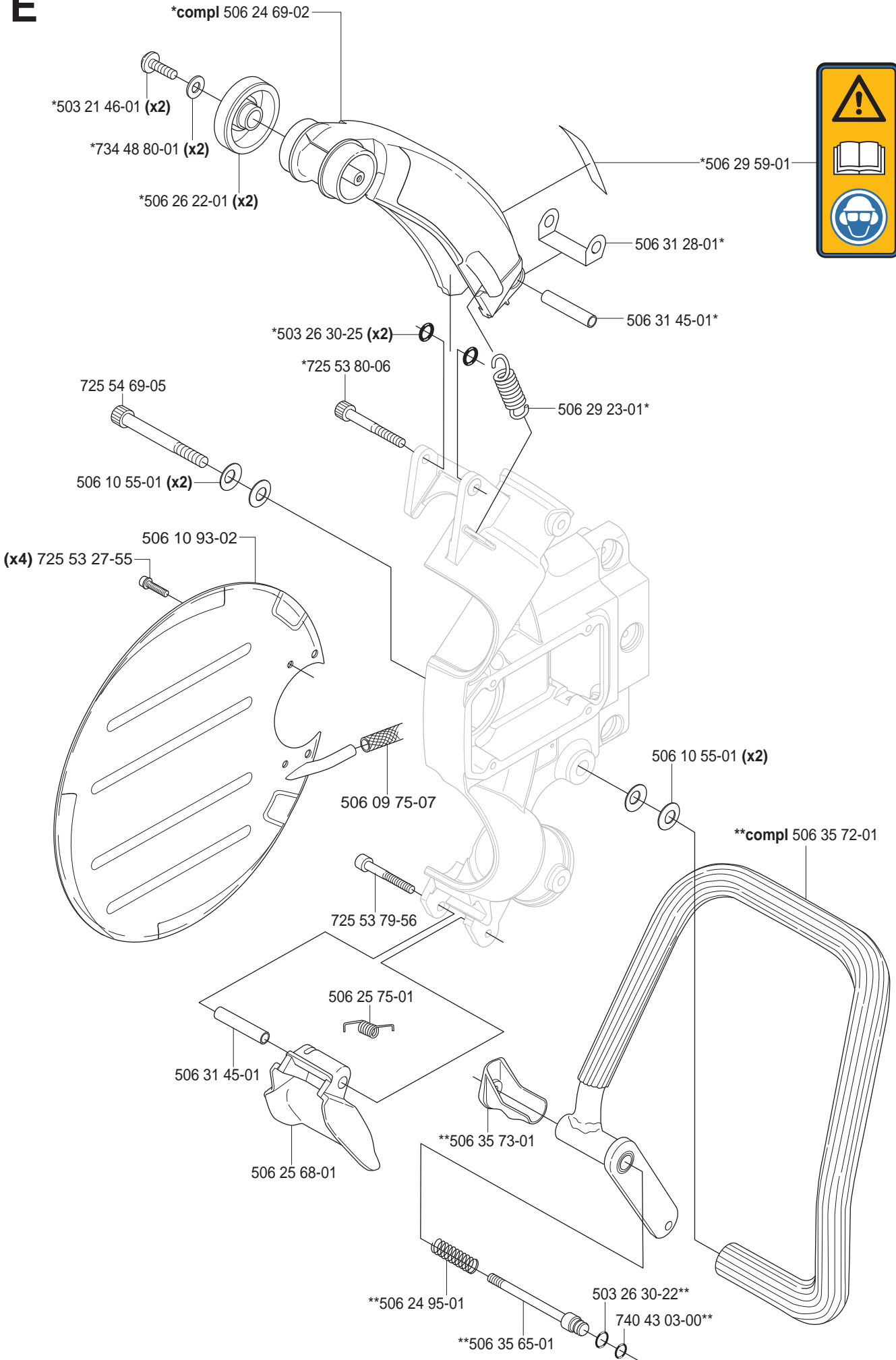

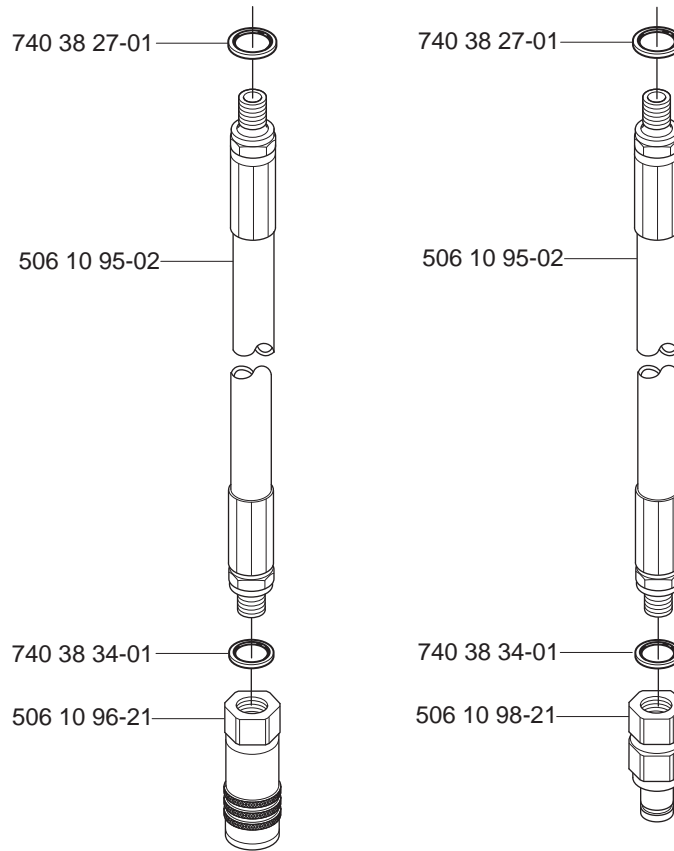
F**G**

Tool kit
*compl 506 36 38-02

