

# ***PARTNER***

Illustrated Parts List 2000-05 cd

***K500 Mark II***      1987-1994

***K540***                      1995-1998

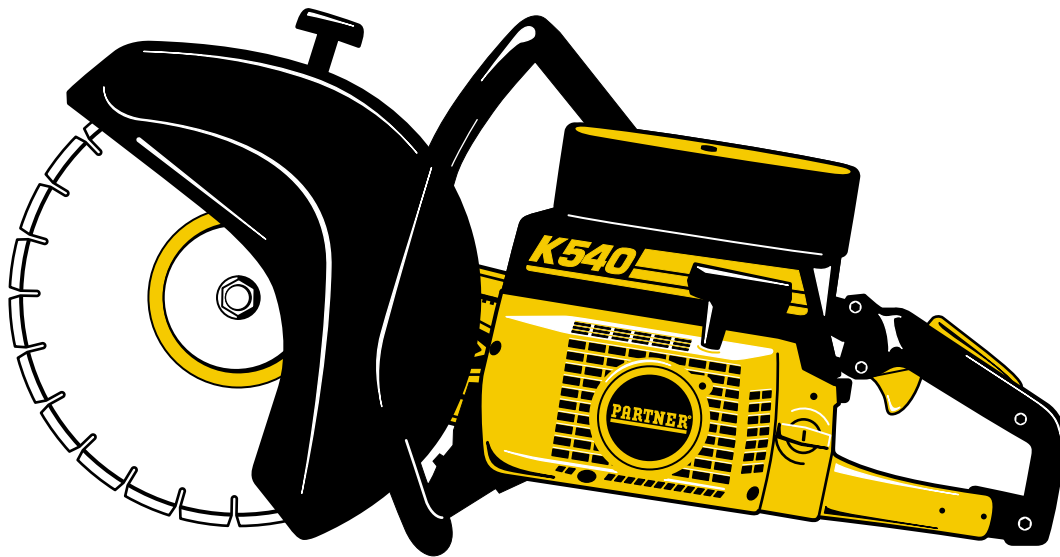

108 30 00-30

---

**PARTNER®**

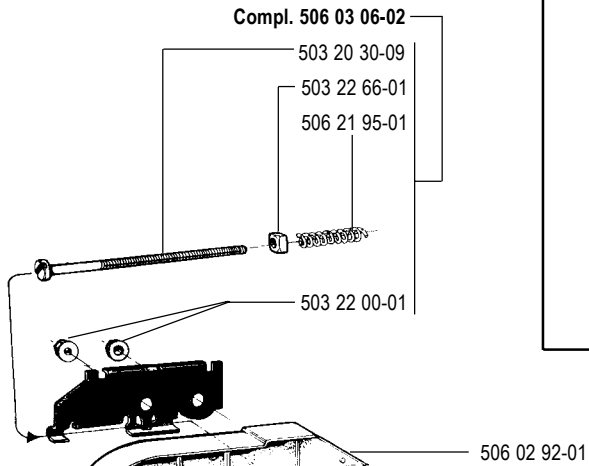
**A**

506 02 92-01

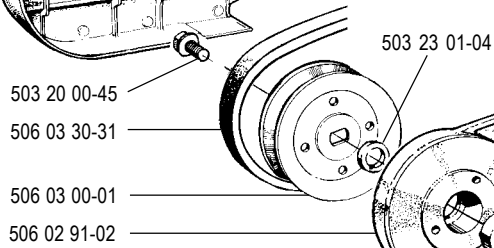

503 20 00-45

506 03 30-31

506 03 00-01

506 02 91-02

503 23 01-04

725 53 27-55

506 14 32-01

506 03 32-02

506 02 86-01

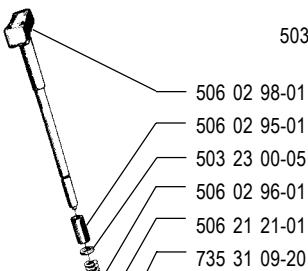

506 02 98-01

506 02 95-01

503 23 00-05

506 02 96-01

506 21 21-01

735 31 09-20

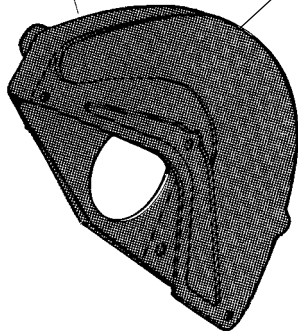
**506 26 00-02 compl. 12"**

503 25 21-01

506 03 62-01

506 02 84-01

506 03 62-02

506 03 62-04

506 03 45-01

725 53 27-55

506 07 07-01 (1/2" wide)

506 02 26-01 (1/4" wide)

Ø 20 mm 506 03 95-20

Ø 7/8", 22.2 506 03 95-22

Ø 1", 25.4 506 03 95-25

Ø 30.5 506 02 88-30

506 29 83-64

506 13 95-11

506 13 96-01

506 02 87-01

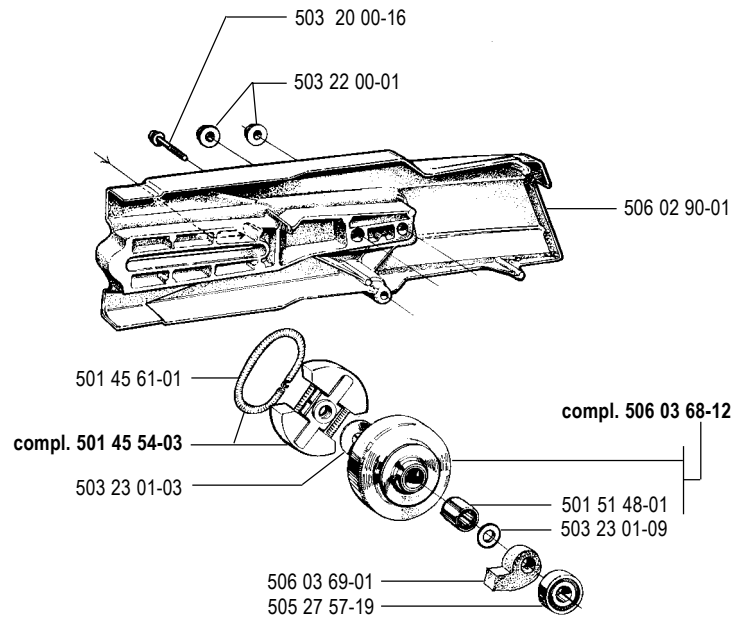
**B**

503 20 00-16

503 22 00-01

506 02 90-01

501 45 61-01

**compl. 501 45 54-03**

503 23 01-03

**compl. 506 03 68-12**

501 51 48-01

503 23 01-09

506 03 69-01

505 27 57-19

**C**

Cyl compl. 503 60 91-02 K540  
 Cyl compl. 506 07 44-01 K500

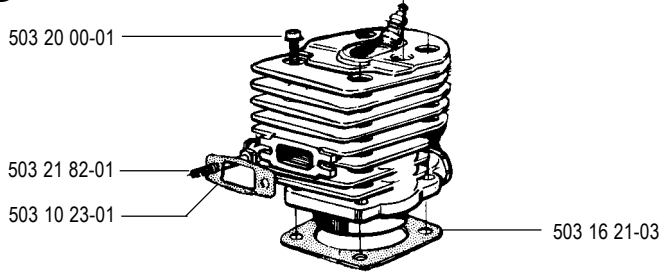

Piston compl. 503 60 81-01 K540  
 506 07 43-01 K500

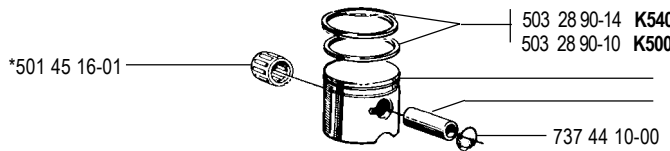
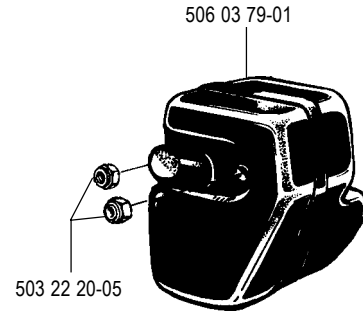
**D****E**

\*Crank shaft comp. 503 57 38-06  
 Note: K500, Before s/n: 013 0003  
 Use part #: 503 11 21-01

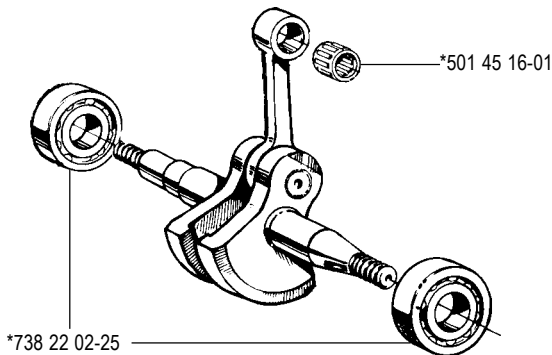
**F**

Carb Compl. 503 28 15-07  
 Adjustment: L = 1  
 H = 1

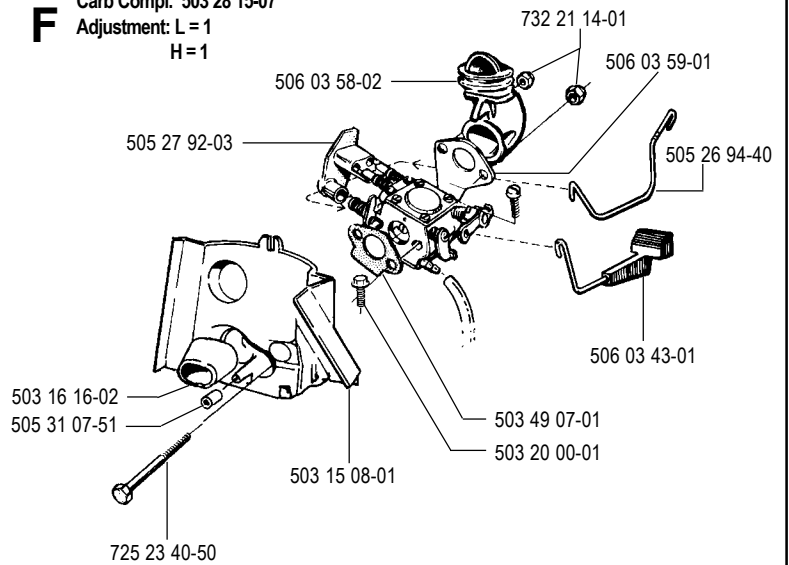
**G**

\*Crank Case compl. 506 07 67-01

Gasket Kit Compl.: 503 15 37-01

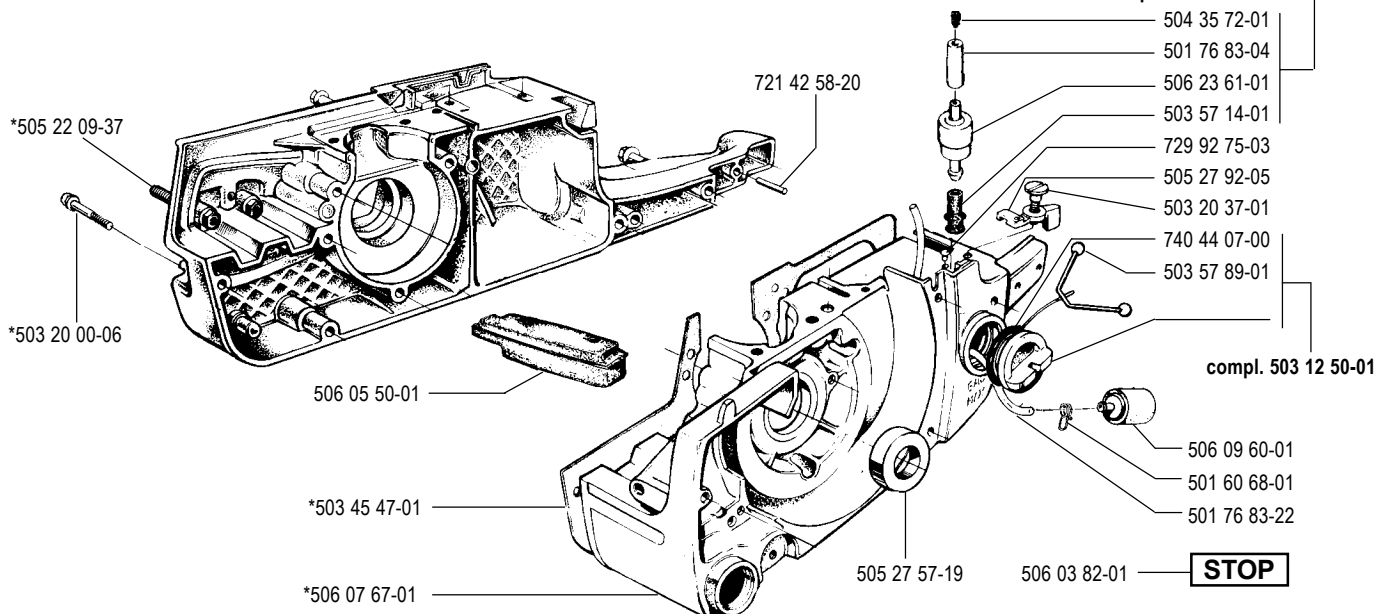

# H

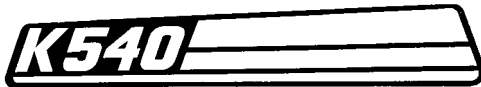
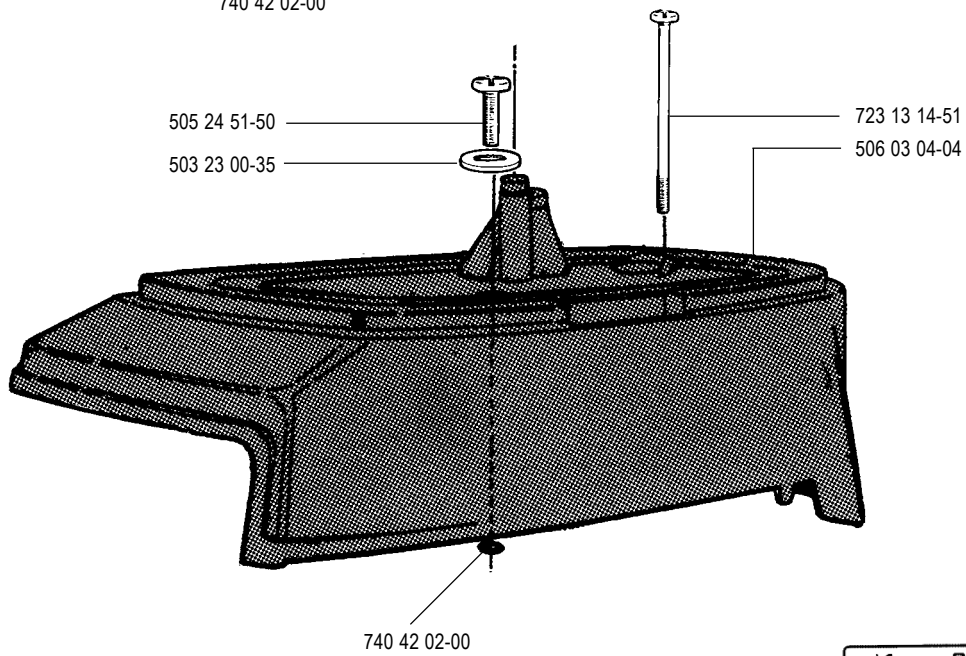
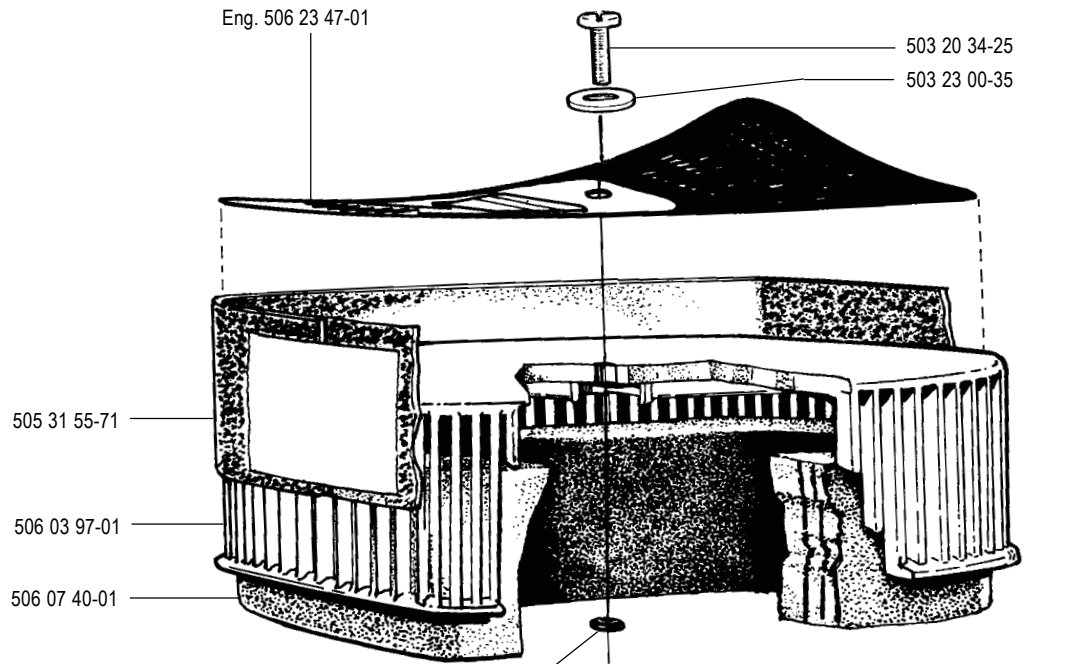

506 23 49-01 K540  
506 14 18-01 K500

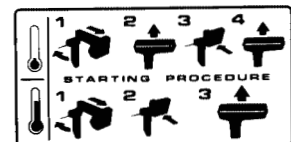

505 39 75-74

I

\* Starter compl. 506 09 50-02

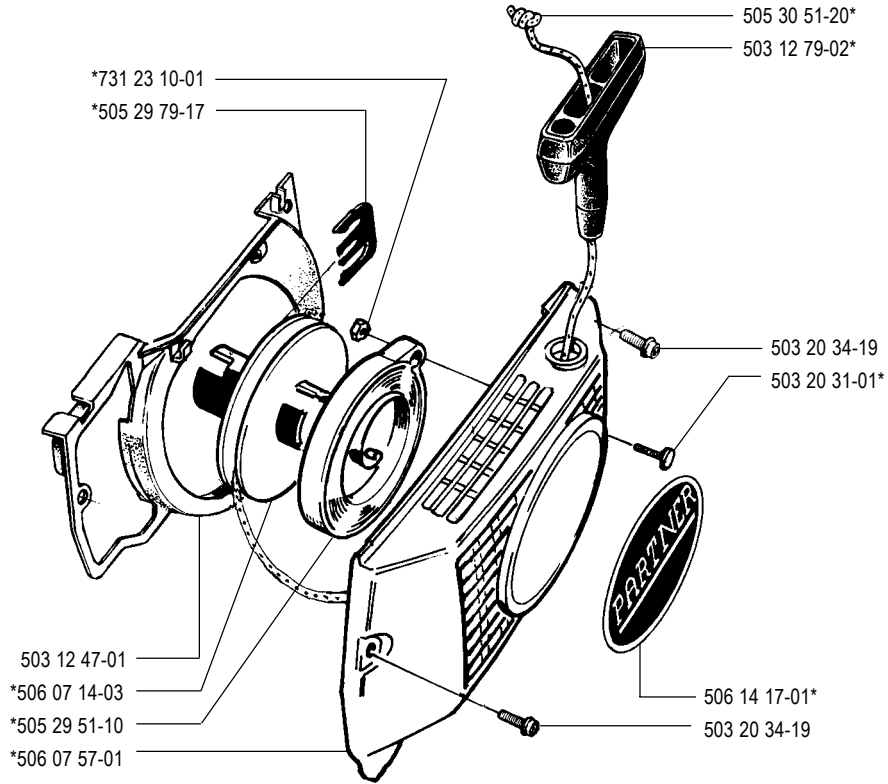

J

501 48 54-02  
RCJ 7Y 503 23 51-08

**Note:**

The green ignition is equipped with a governor. Always use the green ignition on the **K500**

The K540 has a black ignition system as std. Black or green ign. can be used on the **K540** as replacement.

**Flywheel compl.**

506 13 93-01

**Note:**

K500, before s/n: 013 0003  
compl. 506 09 52-01

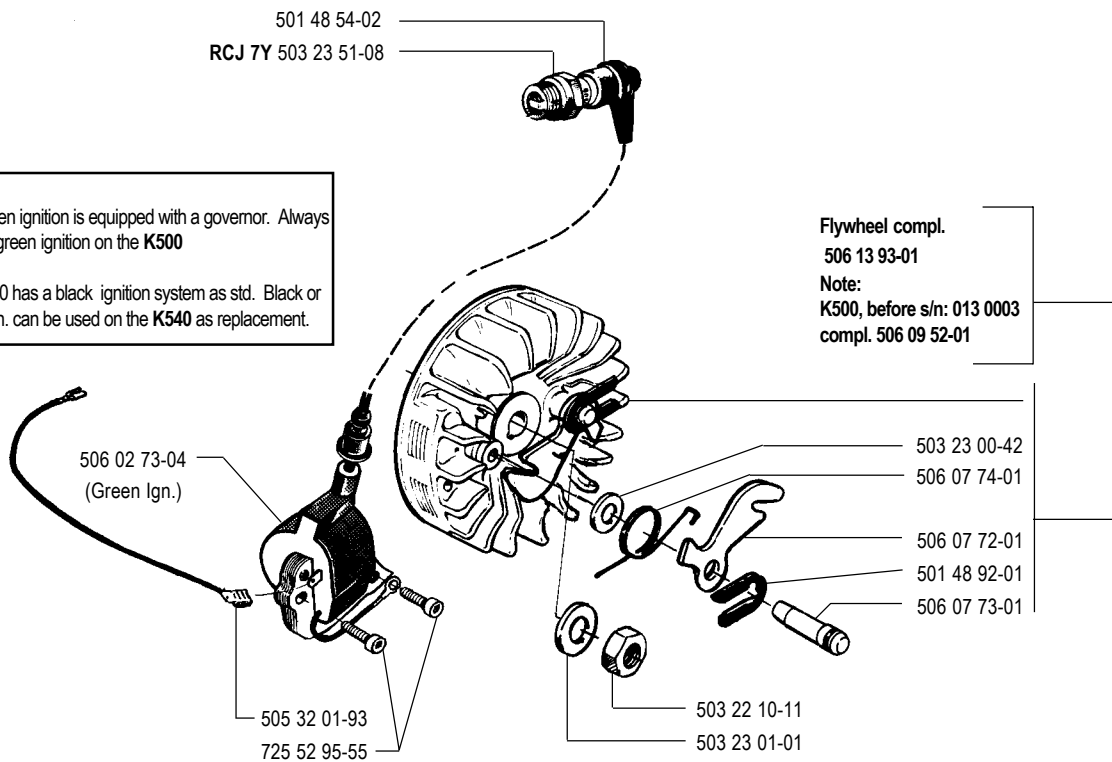

# K

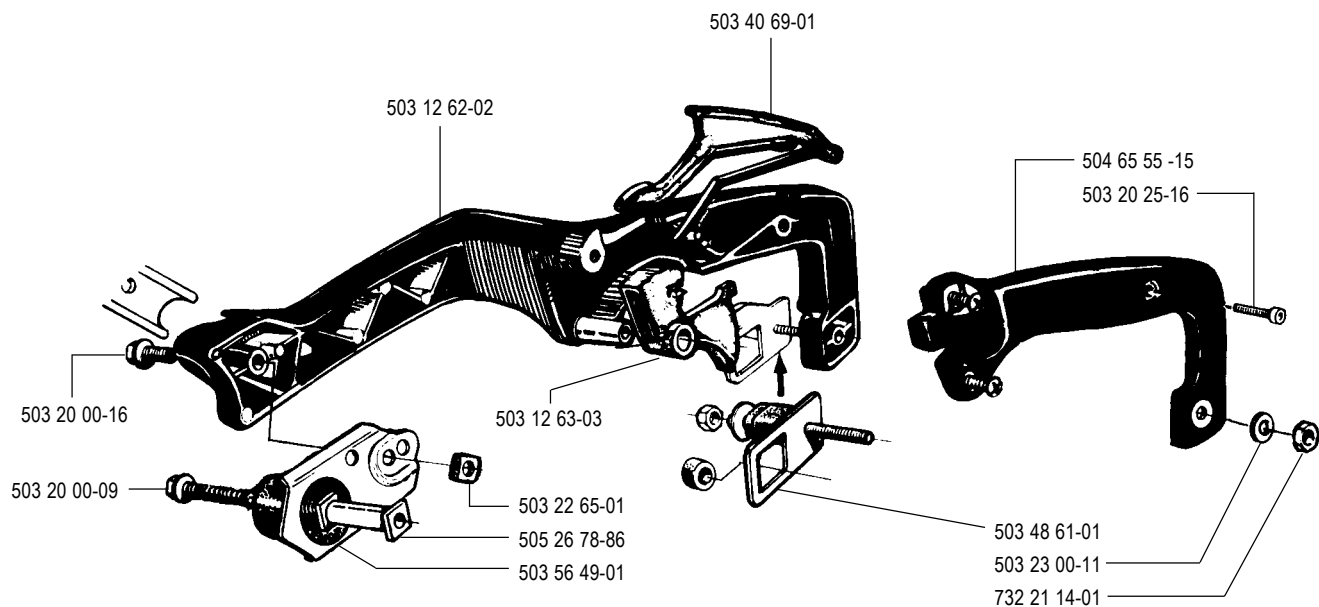

# L

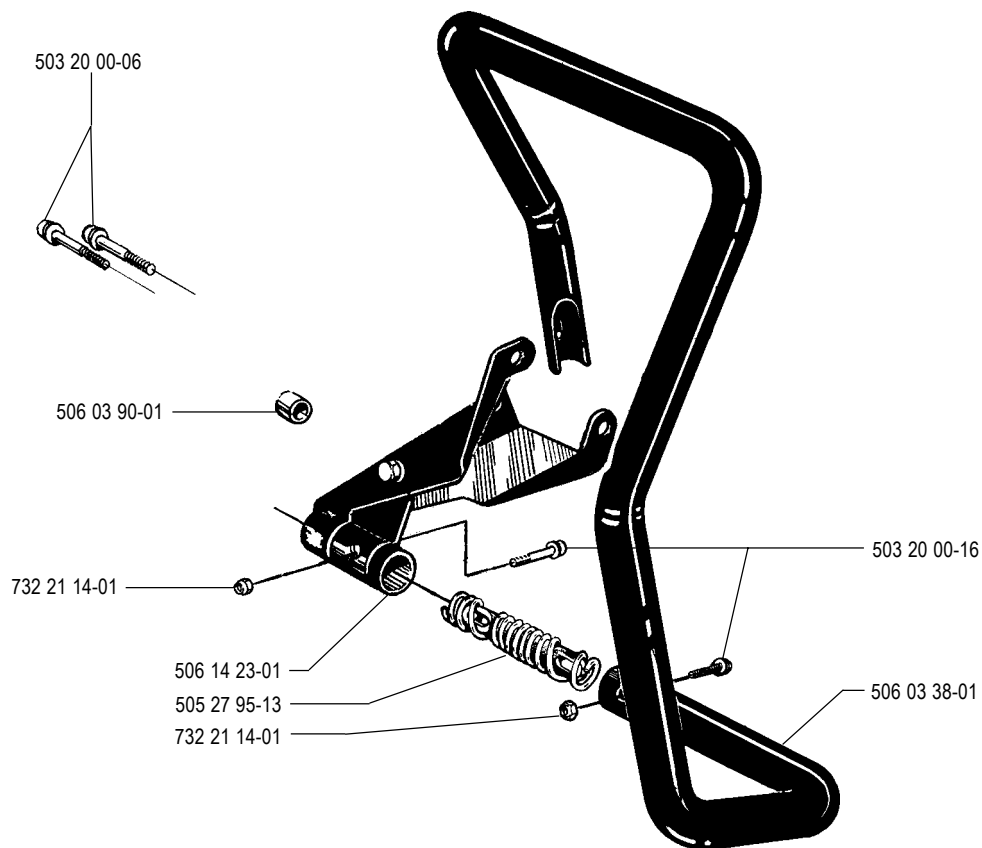

# M

Compl. 503 28 15-07  
Walbro WT 353

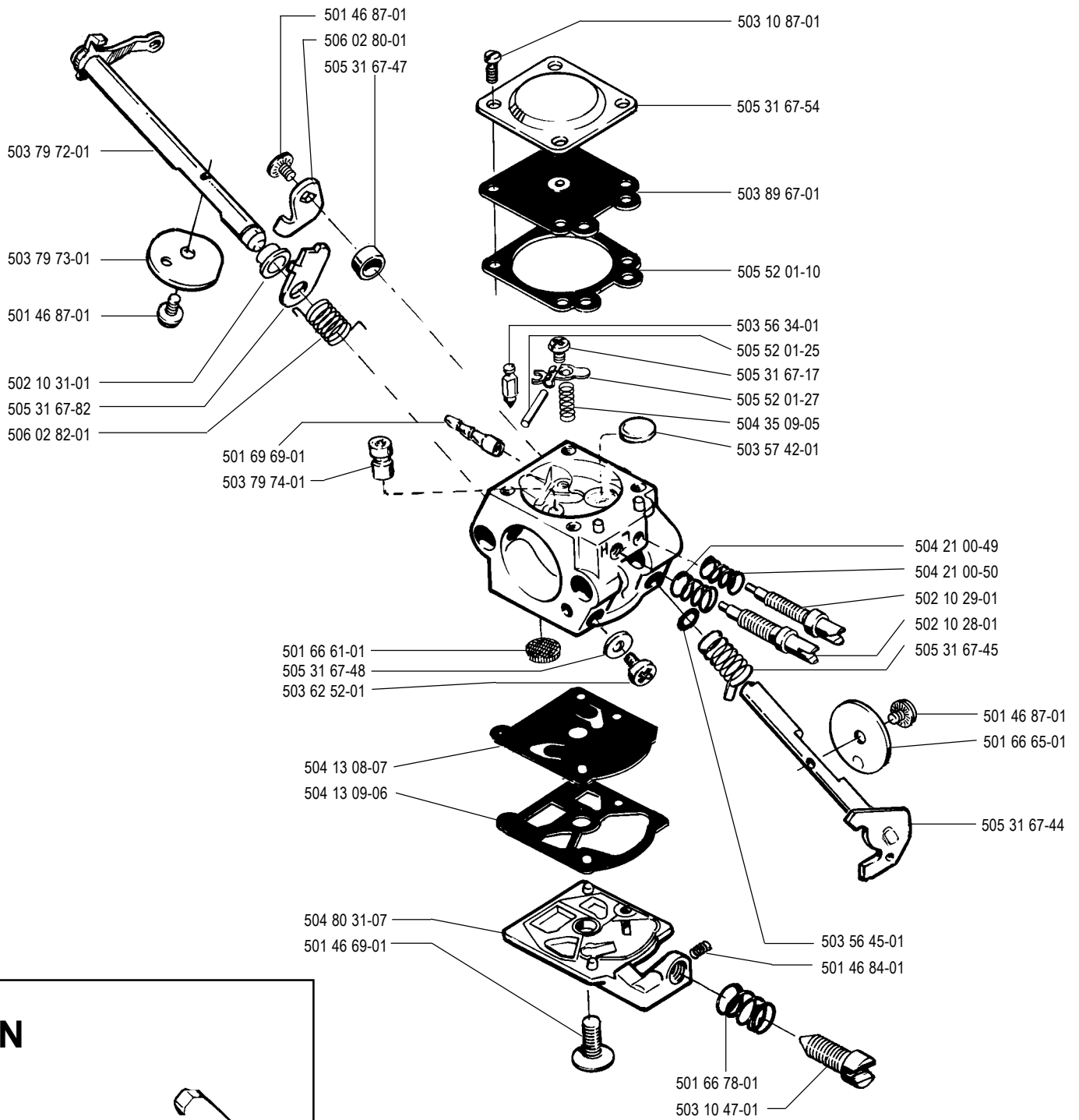

# N

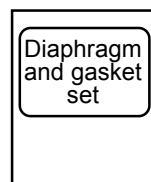
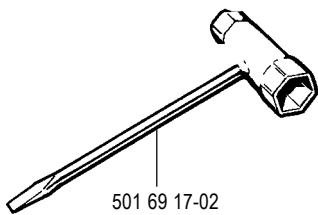

502 10 55-01

502 10 35-01

No.	Pos.	Description	No.	Pos.	Description	No.	Pos.	Description
501 45 16-01	C,E	Support bushing	503 40 69-01	K	Latch	506 03 00-01	A	Pulley
501 45 54-03	B	Clutch cpl	503 45 47-01	G	Gasket	506 03 04-04	H	Cylinder cover
501 45 61-01	B	Spring	503 48 61-01	K	Absorber	506 03 06-02	A	Adjuster
501 46 69-01	M	Screw	503 49 07-01	F	Gasket	506 03 30-31	A	V-belt
501 46 84-01	M	Spring	503 56 34-01	M	Inlet needle	506 03 32-02	A	Screw
501 46 87-01	M	Screw	503 56 45-01	M	Sealing ring	506 03 38-01	L	Handle
501 48 54-02	J	Spark plug conn. kit	503 56 49-01	K	Vibr. absorber	506 03 43-01	F	Choke control
501 48 92-01	J	Retaining ring	503 57 14-01	G	Venting hose	506 03 45-01	A	Washer
501 51 48-01	B	Support bushing	503 57 38-06	E	Crankshaft	506 03 58-02	F	Induction pipe
501 60 68-01	G	Clamp	503 57 42-01	M	Welch plug	506 03 59-01	F	Reinforcement stay
501 66 61-01	M	Screen	503 57 89-01	G	Holder	506 03 62-01	A	Spacer
501 66 65-01	M	Throttle flap	503 60 81-01	C	Piston cpl. 46 mm	506 03 62-02	A	Spacer
501 66 78-01	M	Spring	503 60 91-02	C	Cylinder cpl	506 03 62-04	A	Spacer
501 69 17-02	N	Comb. tool	503 62 52-01	M	Screw	506 03 68-12	B	Worm wheel
501 69 69-01	M	Nipple	503 79 72-01	M	Choke shaft	506 03 69-01	B	Dust protection
501 76 83-04	G	Hose	503 79 73-01	M	Disc	506 03 73-04	J	Ignition module
501 76 83-22	G	Hose, 160 mm	503 79 74-01	M	Valve	506 03 79-01	D	Silencer
502 10 28-01	M	High-speed needle	503 89 67-01	M	Metering diaphragm	506 03 82-01	G	Label
502 10 29-01	M	Low-speed needle	504 13 08-07	M	Pump diaphragm	506 03 90-01	L	Spacer
502 10 31-01	M	Bushing	504 13 09-06	M	Gasket	506 03 95-20	A	Bushing
502 10 35-01	M	Diaphragm kit	504 21 00-49	M	Spring, H-needle	506 03 95-22	A	Bushing
502 10 55-01	M	Carburetor repair kit	504 21 00-50	M	Spring, L-needle	506 03 95-25	A	Bushing
503 10 23-01	C	Gasket	504 35 09-05	M	Spring	506 03 97-01	H	Filter cover
503 10 47-01	M	Screw	504 35 72-01	G	Fuel filter	506 05 50-01	G	Grommet
503 10 87-01	M	Screw with washer	504 65 55-15	K	Handle left	506 07 07-01	A	Flange, support
503 11 21-01	E	Crankshaft (early K500)	504 80 31-07	M	No longer available	506 07 11-13	G	Hose
503 12 47-01	I	Air conductor	505 22 09-37	G	Bar bolt	506 07 14-03	I	Starter pulley
503 12 50-01	G	Tank cap, cpl	505 24 51-50	H	Screw	506 07 40-01	H	Filter
503 12 62-02	K	Handle, right	505 26 78-86	K	Spacer	506 07 43-01	C	Piston cpl K500
503 12 63-03	K	Throttle trigger	505 26 94-40	F	Throttle rod	506 07 44-01	C	Cylinder cpl K500
503 12 79-02	I	Starter handle	505 27 57-19	B,G	Seal ring	506 07 57-01	I	Starter housing
503 15 08-01	F	Heat shield	505 27 92-03	F	Sleeve	506 07 67-01	G	Crankcase cpl
503 15 37-01	G	Gasket kit	505 27 92-05	G	Stop button	506 07 72-01	J	Ratchet
503 16 16-02	F	Induction pipe	505 27 95-13	I	Absorber	506 07 73-01	J	Pin
503 16 21-03	C	Gasket	505 29 51-10	I	Recoil spring	506 07 74-01	J	Spring
503 20 00-01	C,F	Screw M6SF 5x20	505 29 79-17	I	Lock spring	506 09 50-02	I	Starter Ass'y
503 20 00-06	G,L	Screw M6SF 5x35	505 30 51-20	I	Starter rope	506 09 52-01	J	Flywheel cpl (early K500)
503 20 00-09	K	Screw M6SF 5x35	505 31 07-51	F	Impulse pipe	506 09 60-01	G	Filter
503 20 00-16	B,K,L	Screw M6SF 5x28	505 31 55-71	H	Pre-filter	506 13 93-01	J	Flywheel cpl
503 20 00-45	A	Screw	505 31 67-17	M	Screw	506 13 95-01	A	Washer
503 20 25-16	K	Screw	505 31 67-44	M	Throttle shaft	506 13 96-01	A	Screw
503 20 30-09	A	Screw	505 31 67-45	M	Spring	506 14 17-01	I	Decal
503 20 31-01	I	Screw LKCS 3x10	505 31 67-47	M	Bushing	506 14 18-01	H	Decal K500
503 20 34-19	I	Screw	505 31 67-48	M	Washer	506 14 23-01	L	Support
503 20 34-25	H	Screw	505 31 67-54	M	Diaphragm cover	506 14 32-01	A	Catch
503 20 37-01	G	Screw 5x10	505 31 67-82	M	Starter lever	506 21 21-01	A	Washer
503 21 82-01	C	Square head screw 5x57	505 32 01-93	J	Cable	506 21 95-01	A	Spring
503 22 00-01	A,B	Nut M6MF M8	505 39 75-74	H	Label start-instr.	506 23 47-01	H	Decal
503 22 10-11	J	Nut M8x1	505 52 01-10	M	Gasket, metering side	506 23 49-01	H	Decal
503 22 20-05	D	Nut	505 52 01-25	M	Fulcrum pin	506 23 61-01	G	Tank vent.
503 22 65-01	K	Square Nut M5	505 52 01-27	M	Lever	506 26 00-02	A	Guard
503 22 66-01	A	Nut	506 02 26-01	A	Bushing (early)	721 42 58-20	G	Spring pin 4x24
503 23 00-05	A	Washer 6.5x11	506 02 80-01	M	Starter lever	723 13 14-51	H	Screw 4x95
503 23 00-11	K	Washer 5.3x12	506 02 82-01	M	Spring	725 23 40-50	F	Screw M6S 5x45
503 23 00-35	H	Washer 5.3x15	506 02 84-01	A	Washer	725 52 95-55	J	Screw MC6S 4x20
503 23 00-42	J	Washer	506 02 85-63	A	Shaft	725 53 27-55	A	Screw MC6S 5x12
503 23 01-01	J	Washer 8.4x16	506 02 86-01	A	Spacer	729 92 75-03	G	Screw KDS 6x6
503 23 01-03	B	Washer 10x36	506 02 87-01	A	Washer	731 23 10-01	I	Nut N6M M3
503 23 01-04	A	Washer 15x21	506 02 88-30	A	Bushing	732 21 14-01	F,K,L	Locknut M5
503 23 01-09	B	Washer	506 02 90-01	B	Cutting arm	735 31 09-20	A	E-ring 5
503 23 51-08	J	Spark plug RCJ7Y	506 02 91-02	A	Bearing housing	737 44 10-00	C	Locking ring
503 25 21-01	A	Ball bearing 6202 DDU/C3	506 02 92-01	A	Guard	738 22 02-25	E	Ball bearing 6202-C3
503 28 15-07	F,M	Carburettor	506 02 95-01	A	Hose	740 42 02-00	H	O-ring
503 28 90-10	C	Piston ring K500	506 02 96-01	A	Spring	740 44 07-00	G	O-ring
503 28 90-14	C	Piston ring K540	506 02 98-01	A	Control knob			