

Ersatzteilliste
Spare parts list

Liste de pièces de rechange
Lista de piezas de recambio

Motorsensen 118 / 119
Brushcutters
Debroussailleuses
Desmalezadoras

MADE IN GERMANY
MADE BY SOLO



Zeichenerklärung Legend

ØXXXXX Bis Serien-Nr.
XXXXXØ Ab Serien-Nr.
+ Neues Teil gegenüber D 9 118 700
*+ Neues Teil gegenüber D 9 118 700,
mit Bezug auf Serien-Nr.

up to serial no.
as of serial no.
new part compared to D 9 118 700
new part compared to D 9 118 700,
referring to serial no.

Légende

jusqu'au no. de série
à partir de no. de série
nouvelle pièce par rapport à D 9 118 700
nouvelle pièce par rapport à D 9 118 700,
se référant au no. de série

Leyenda

hasta no. de serie
desde de no. de serie
parte nuevo comparado con D 9 118 700
parte nuevo comparado con D 9 118 700,
referente al no. de serie

D 9 118 701

solo®

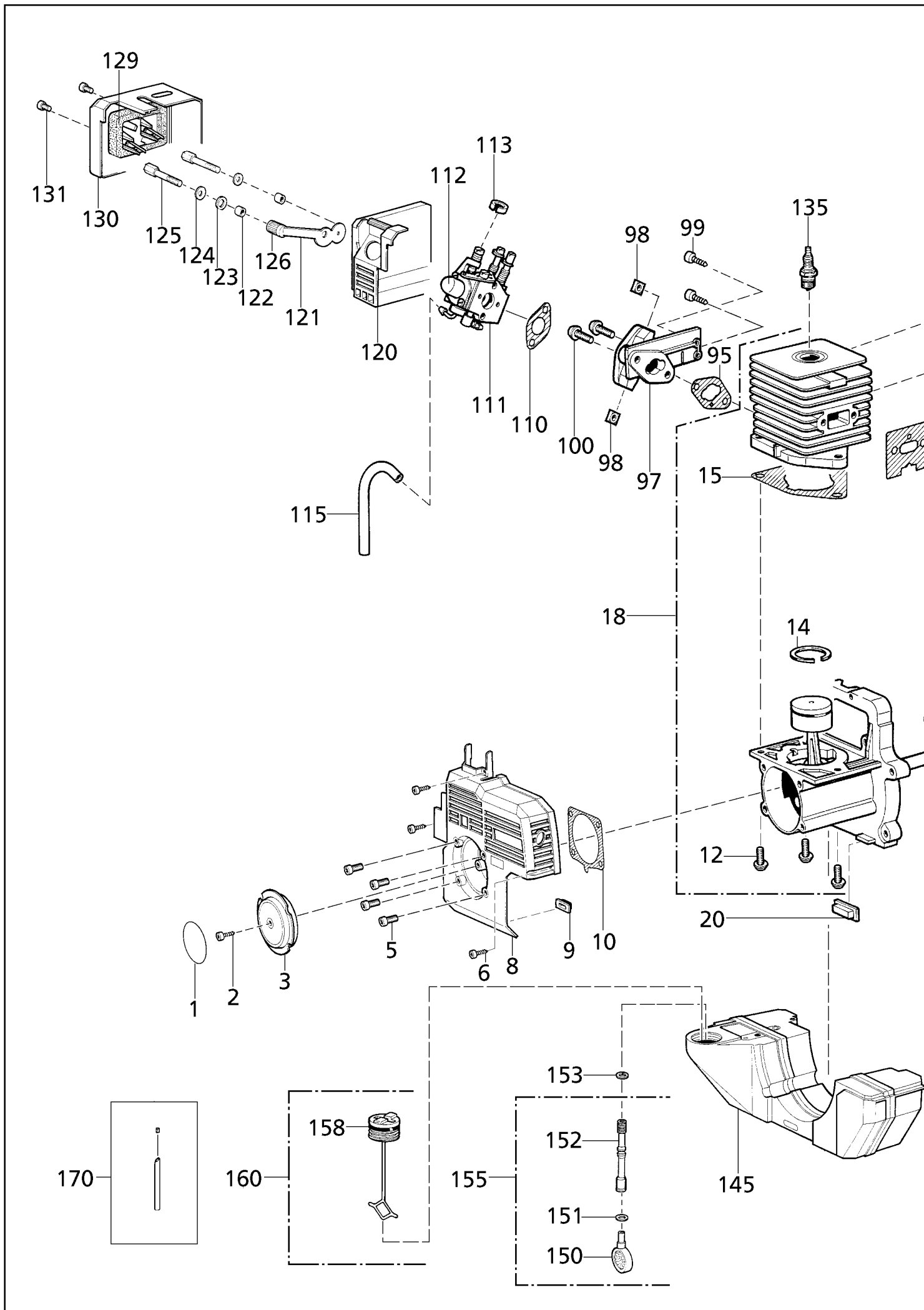

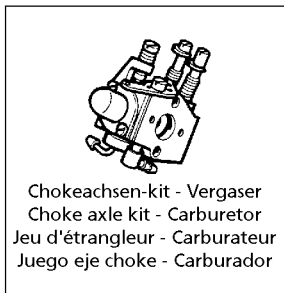
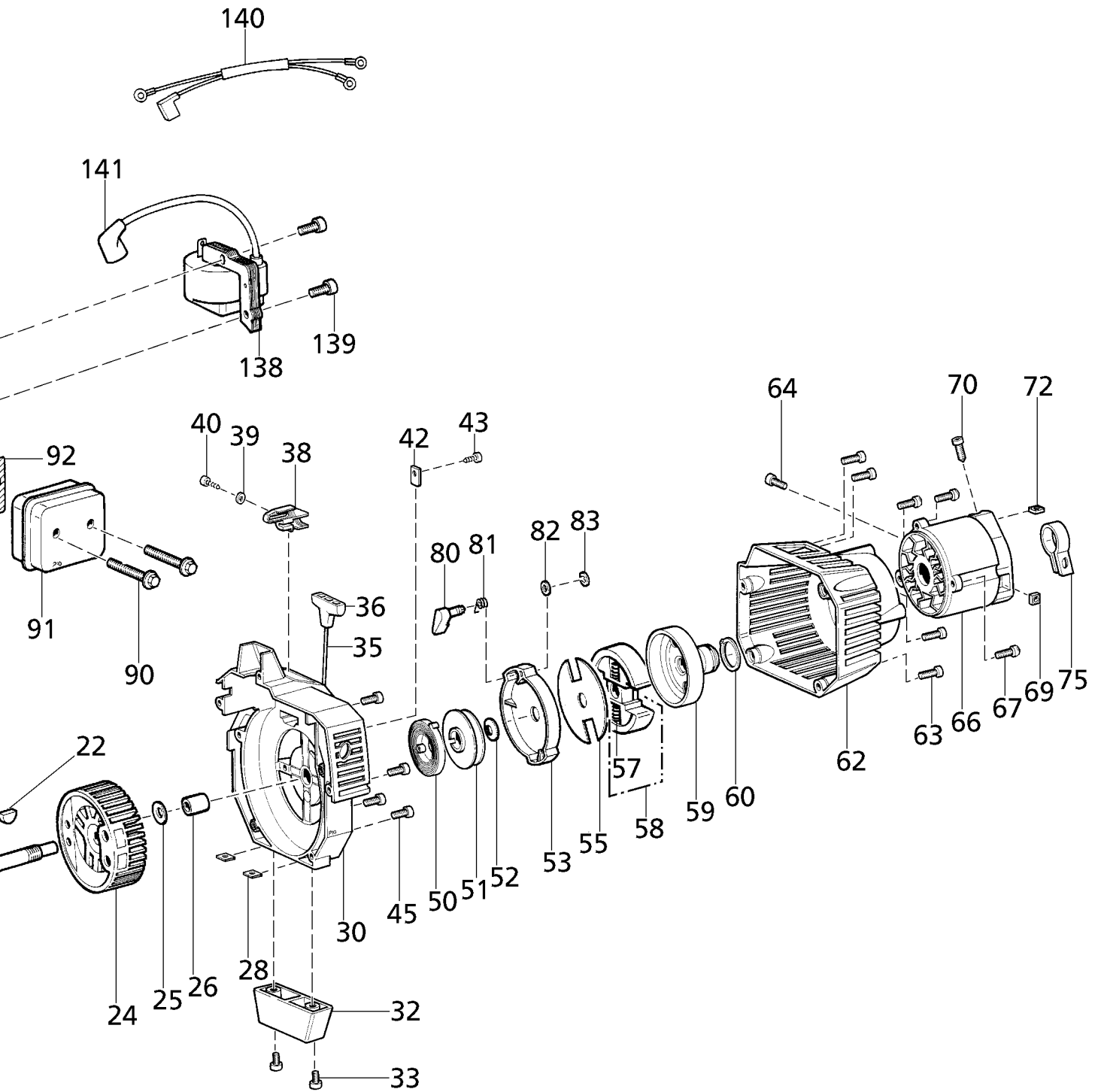

180

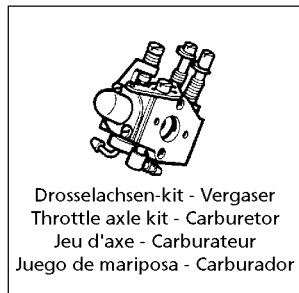

181

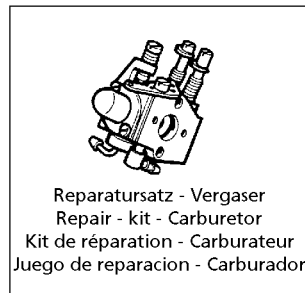

182

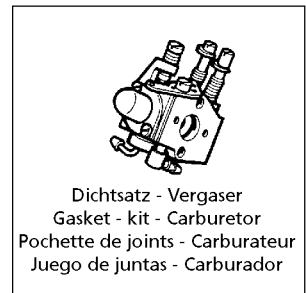

183

Bild-Nr. Pos.-No. Pos.-No.	Bestell-Nr. Order-No. No. de Cde. Ref.-Nr.	Modell Type Modèle Modelo	Menge Quantity Nombres Cantidad	Motor/ Gehäuse	Engine/ Housing	Moteur/ Carter	Motor/ Carter
1	00 69 890		1	Selbstklebeschild "SOLO", Ø 42 mm	sticker "SOLO"	autocollant "SOLO"	adhesivo "SOLO"
2	00 18 355		1	Linsenschraube 4x16	screw	vis	tornillo
3	20 74 957		1	Abdeckung	cover	couvercle	cubierta
5	00 18 402		4	Zylinderschraube 10-24x18	screw	vis	tornillo
6	00 18 355		3	Linsenschraube 4x16	screw	vis	tornillo
8	20 73 664		1	Haube 2	cover 2	couvercle 2	cubierta 2
9	00 94 274		1	Puffer	rubber buffer	butée caoutchouc	tope de goma
10	20 61 497		1	Kurbelgehäusedichtung	crankcase gasket	joint de carter	junta de carter
12	00 18 291		3	Linsenschraube 10-24x0,875	screw	vis	tornillo
14	20 48 331		1	Kolbenring	piston ring	segment de piston	anillo de piston
15	20 63 306		1	Zylinderfußdichtung	cylinder gasket	joint de cylindre	empaque del cilindro
18	20 00 453		1	Shortblock (enth.:	shortblock (incl.:	shortblock (incl.:	motor (incl.:
(12)	00 18 291			Linsenschraube 10-24x0,875	screw	vis	tornillo
(14)	20 48 331			Kolbenring	piston ring	segment de piston	anillo de piston
(15)	20 63 306			Zylinderfußdichtung	cylinder gasket	joint de cylindre	empaque del cilindro
				Kolben, Ø 33 mm + Pleuel	piston + rod	piston + bielle	piston
				Zylinder, Ø 33 mm	cylinder	cylindre	cilindro
				Kurbelwelle	crankshaft	vilebrequin	cigüenal
				Kurbelgehäuse)	crankcase)	carter-motuer)	carter cigüenal)
20	00 94 274		1	Puffer	rubber buffer	butée caoutchouc	tope de goma
22	00 75 135		1	Scheibenfeder	disc spring	clavette	cuna
24	24 00 293		1	Lüfterrad	fan wheel	turbine	turbina
25	00 72 120		1	Tellerfeder 10,2x20x1,1 DIN 2093	spring washer	rondelle plat	resorte
26	00 33 372		1	Distanzrohr 12x1,2x49	tube	tube	tubo
28	00 28 149		2	Blechmutter 4,8	nut	écrou	tuerca
30	21 00 596		1	Haube 1	cover 1	couvercle 1	cubierta 1
32	20 73 602		1	Stützleiste	support strip	nervure renforcement	soporte
33	00 18 370		2	Linsenschraube 6x20	screw	vis	tornillo
35	00 63 195		1	Starterseil	starter rope	corde de lanceur	cuerda de arranque
35	00 63 170 +		1	Starterseil	starter rope	corde de lanceur	cuerda de arranque
36	20 74 569		1	Startergriff	starter grip	poignée lanceur	empunadura arranque
38	60 74 974		1	Widerlager	abutment	butée	cojinet de tope
39	00 72 140		1	Tellerfeder 5,2x12x0,5 DIN 2093A	spring disc	rondelle plat	arandela
40	00 18 274		1	Linsenschraube 5x16	screw	vis	tornillo
42	20 42 839		1	Halteblech	fixing plate	tôle de fixation	chapa fijacion
43	00 18 354		1	Linsenschraube 4x12	screw	vis	tornillo
45	00 18 403		4	Zylinderschraube 10-24x35	screw	vis	tornillo
50	26 00 285		1	Federkassette	spring cassette	cassette de ressort	caja de resorte
51	20 74 971		1	Seilrolle	rope pulley	poulie de corde	roldana
52	00 72 120		1	Tellerfeder 10,2x20x1,1 DIN 2093	spring washer	rondelle plat	resorte
53	20 12 876		1	Anwurfrolle	starter pulley	poulie de lancement	roldana
55	00 31 601		1	Kupplungsscheibe 9,5/48x0,5	washer, clutch	rondelle d'embrayage	arandela de embrague
57	00 70 258		2	Kupplungsfeder 1,4x6,2x14	clutch spring	ressort d'embrayage	muelle
58	35 00 423		1	Fliehkraftkupplung	clutch	embrayage	embrague
59	35 00 424		1	Kupplungsglocke	clutch drum	cloche d'embrayage	campana de embrague
60	00 55 136		1	Sicherungsring 15x1 DIN 477	circlip	circlip	anillo
62	61 00 377		1	Flanschgehäuse mit Lager	flange housing	carter bride	presilla
63	00 18 363		4	Linsenschraube 5x20	screw	vis	tornillo
64	00 18 338		1	Zylinderschraube M5x25	screw	vis	tornillo
66	20 74 972		1	Klemmstück	clamp	collier	abrazadera
67	00 18 363		3	Linsenschraube 5x20	screw	vis	tornillo
69	00 21 241		1	Vierkantmutter M5	nut	écrou	tuerca
70	00 18 405		1	Zylinderschraube M5x14,5	screw	vis	tornillo
72	00 21 241		1	Vierkantmutter M5	nut	écrou	tuerca
75	00 66 457		1	Schelle 24x14	clamp	collier de serrage	abrazadera
80	20 74 967		1	Starterklinke	starter pawl	cliquet lanceur	trinquete
81	00 73 401		1	Schenkelfeder 0,4x6	spring	ressort	resorte
82	00 31 607		1	Anlaufscheibe 5,1x8x0,3 DIN 988	washer	rondelle	arandela
83	00 55 103		1	Sicherungsscheibe 3,2 DIN 6799	washer	rondelle	arandela
90	00 18 286		2	Sechskantschraube 10-24x2,5"	screw	vis	tornillo
91	25 00 701		1	Auspuff	muffler	échappement	escape
92	20 42 764		1	Auspuffdichtung	gasket, muffler	joint d'échappement	junta escape
95	20 61 489		1	Vergaserflanschdichtung, 1,0 mm	manifold gasket	joint bride carburateur	junta de brida carburador
97	20 74 968		1	Ansaugstutzen	intake manifold	pipe d'aspiration	munon
98	00 21 235		2	Vierkantmutter M5	nut	écrou	tuerca
99	00 18 355		2	Linsenschraube 4x16	screw	vis	tornillo
100	00 18 402		2	Zylinderschraube 10-24x18	screw	vis	tornillo
110	20 61 491		1	Vergaserdichtung	gasket, carburetor	joint, carburateur	junta carburador
111	23 00 740		1	Vergaser WALBRO WT 386	carburetor WALBRO WT 386	carburateur, WALBRO WT 386	carburador, WALBRO WT 386
111	23 00 787 *+		1	Vergaser WALBRO WT 514	carburetor WALBRO WT 514	carburateur, WALBRO WT 514	carburador, WALBRO WT 514
112	05 10 921		1	Kappe	primer cap	capuchon primer	caperuza
113	20 74 905		1	Haltering	retaining ring	bague de support	anillo soporte

Bild-Nr. Pos.-No. Pos.-No.	Bestell-Nr. Order-No. No. de Cde. Ref.-Nr.	Modell Type Modèle Modelo	Menge Quantity Nombres Cantidad	Motor/ Gehäuse	Engine/ Housing	Moteur/ Carter	Motor/ Carter
115	00 64 300		1	Schlauch 3x1,5	tube	tuyau	tubo
120	20 74 912		1	Filtergehäuse	filter housing	carter de filtre	filtro de tapa
121	20 43 998		1	Chokeklappe	choke flap	étrangleur	mariposa
122	00 33 371		2	Distanzrohr 7x0,8x6	tube	tube	tubo
123	00 61 360		1	Scheibe 6,8x10x1,2	washer	rondelle	arandela
124	00 72 140		2	Tellerfeder 5,2x12x0,5 DIN 2093A	spring disc	rondelle plat	muelle de disco
125	00 15 289		2	Stiftschraube M5x47	screw	vis	tornillo
126	20 74 966		1	Chokeknopf	knob	bouton	boton
129	20 48 363		1	Luftfilter	air filter	filtre à air	filtro de aire
130	20 74 911		1	Filterhaube	filter cover	couvercle filtre	cubierta
131	00 18 333		2	Zylinderschraube M5x16	screw	vis	tornillo
135	23 00 743		1	Zündkerze WSR 8F	spark plug	bougie	bujia
138	23 00 741		1	Zündmodul, PHELON	ignition coil	bobine	bobina
139	00 18 401		2	Zylinderschraube 8-32x25	screw	vis	tornillo
140	00 84 672		1	Kurzschlußkabel	short circuit cable	câble court circuit	cable cortocircuito
141	23 00 527 +		1	Kerzenstecker	spark plug cap	capuchon de bougie	caperuza
145	27 00 363		1	Benzintank	fuel tank	réservoir d'essence	deposito de gasolina
150	27 00 285		1	Benzinsucher	fuel pick-up	crépine d'essence	filtro gasolina
151	00 73 374		1	Schlauchöse 8x0,7x1,25	hose fitting	oillet	manguito de cable
152	60 63 332		1	Kraftstoffschlauch 3x95	fuel hose	tube essence	tubo gasolina
153	00 73 351		1	Schlauchöse 6,7x0,9	hose fitting	collier	manguito de cable
155	27 00 368		1	Kraftstofffilter mit Schlauch	fuel filter	filtre essence	filtro gasolina
158	00 62 309		1	O-Ring 25,2x3	o-ring	joint torique	anillo
160	27 00 367		1	Tankverschluß, kompl.	tank cap, compl.	covercle réservoir, compl.	tapa de deposito
170	27 00 383		1	Entlüftungsschlauch mit Ventil	hose with valve	tube et valve	tubo y valvula
180	05 10 975		1	Chokeachsen-kit-Vergaser WT-514	choke axle kit-carburetor	jeu d'étrangleur-carburateur	Juego eje choke-carburador
181	05 10 974		1	Drosselachsen-kit-Vergaser WT-514	throttle axle kit-carburetor	jeu d'axe-carburateur	juego de mariposa-carburador
182	05 10 920		1	Reparatursatz-Vergaser WT-514	repair-kit-carburetor	kit de réparation-carburateur	juego de reparacion-carburador
183	05 10 918		1	Dichtsatz-Vergaser WT-514	gasket-kit-carburetor	pochette de joints-carburateur	juego de juntas-carburador

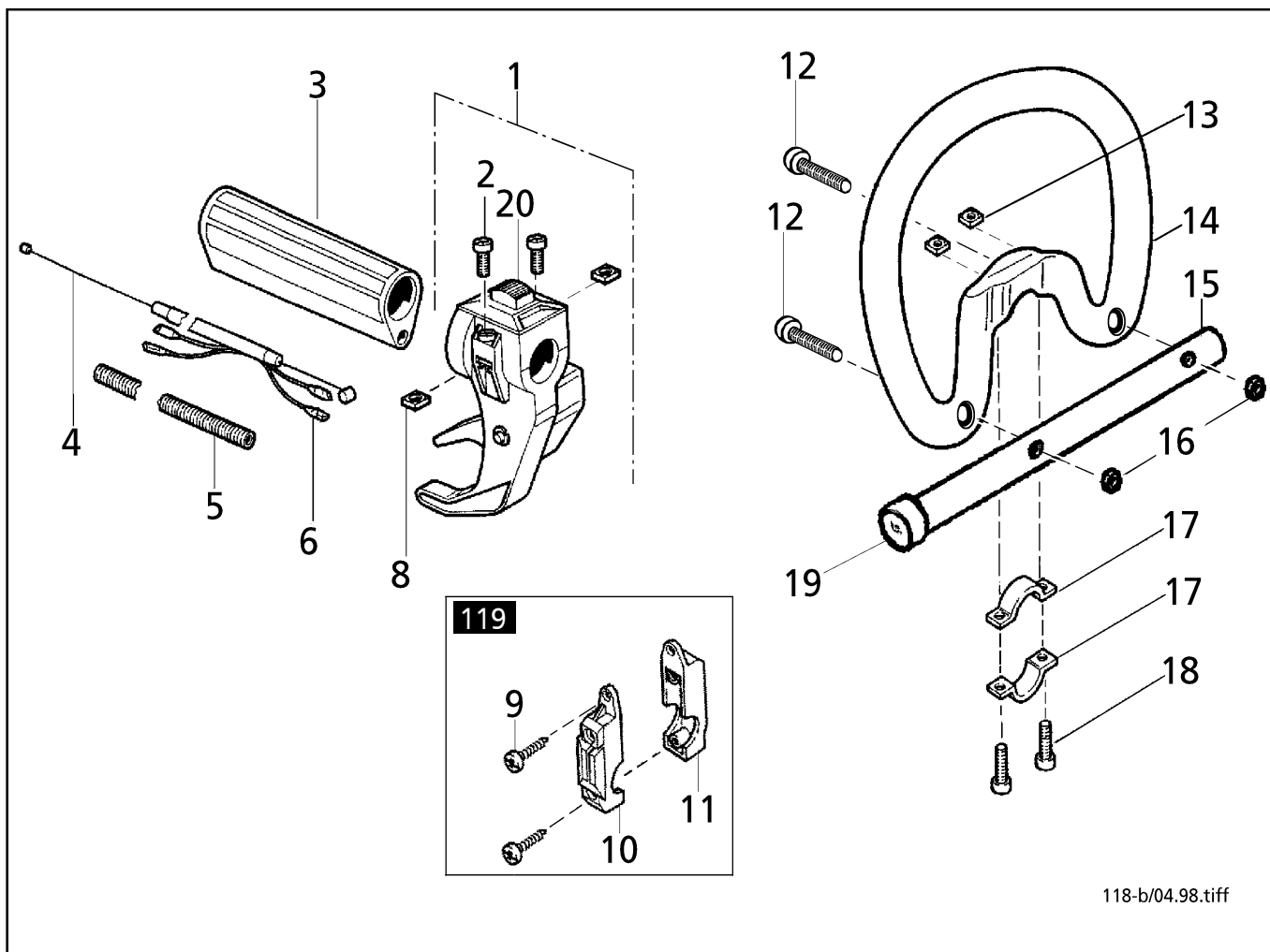

118-b/04.98.tiff

Bild-Nr. Pos.-No. Pos.-No.	Bestell-Nr. Order-No. No. de Cde. Ref.-Nr.	Modell Type Modèle Modelo	Menge Quantity Nombres Cantidad	Griff/ Gasbetätigung	Handle/ Throttle control	Guidon/ Levier régulateur	Empunadura/ Acelerador de gas
1	68 00 306		1	Gasgriff	throttle lever	levier de gaz	palanca gas
2	00 10 182		2	Zylinderschraube M5x20 DIN 84A	screw	vis	tornillo
3	60 63 331		1	Griff 24x125	grip	étrier	empunadura
4	28 00 345		1	Bowdenzug, Gas	bowden cable, gas	câble bowden, gaz	cable de bowden
5	00 64 415 R +		1	Schlauch 8,5x36	tube	tuyau	tubo
6	00 84 673		2	Massekabel	ground cable	câble de masse	cable de masa
8	00 20 160		2	Vierkantmutter M5	nut	écrou	tuerca
9	00 18 357 +	119	2	Linsenschraube 4x25	screw	vis	tornillo
10	20 74 932 +	119	1	Gurtbefestigung 2	harness hook	fixation bretelle	soporte cinturon
11	20 74 931 +	119	1	Gurtbefestigung 1	harness hook	fixation bretelle	soporte cinturon
12	00 18 389		2	Zylinderschraube M5x45	screw	vis	tornillo
13	00 21 241		2	Vierkantmutter M5	nut	écrou	tuerca
14	60 73 584		1	Griffholm	loop handle	guidon-loop	larguero
15	60 35 975		1	Anschlag	stop plate	butée	tope
16	00 28 110		2	Sechskantmutter M5 DIN 980	nut	écrou	tuerca
17	60 43 438		2	Schelle 24	clamp	collier de serrage	abrazadera
18	00 18 338		2	Zylinderschraube M5x25	screw	vis	tornillo
19	20 74 945		1	Verschlussstopfen 12x20	plug	bouchon	tapon
20	68 00 328		1	Kurzschlußschalter, Gasgriff	switch	interrupteur	interruptor

119

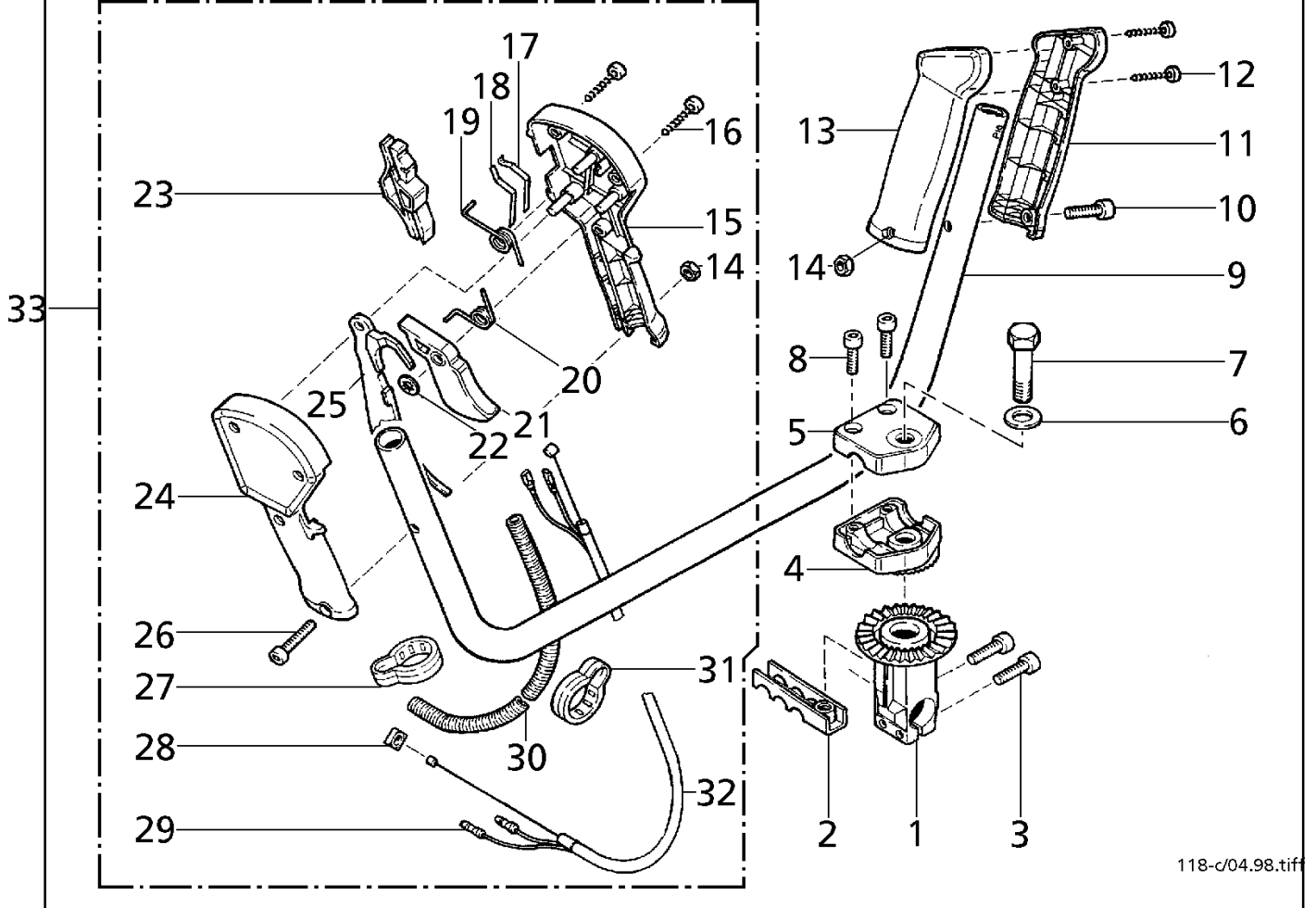

118-c/04.98.tif

Bild-Nr. Pos.-No. Pos.-No.	Bestell-Nr. Order-No. No. de Cde. Ref.-Nr.	Modell Type Modèle Modelo	Menge Quantity Nombres Cantidad	Griffrohr/ Gasbetätigung	Double handle/ Throttle control	Poignée guidon/ Levier régulateur	Tubo/ Acelerador de gas
1	60 12 843		1	Klemmhalter, Ø 24 mm	circlip	reteneur	retenedor
2	68 00 264		1	Gurtbefestigung	strap holder	porte-bretelle	hebillas para correa
3	00 18 337		2	Zylinderschraube M5x20	screw	vis	tornillo
4	60 12 836		1	Klemmschale, für Ø 22 mm	handlebar clamp	plaque de serrage guidon	abrazadera
5	60 12 837		1	Klemmschale, für Ø 22 mm	handlebar clamp	plaque de serrage guidon	abrazadera
6	00 30 128		1	Scheibe 8,4 DIN 9021A	washer	rondelle	arandela
7	00 12 376		1	Sechskantschraube M8x65, SW19	screw	vis	tornillo
8	00 18 337		2	Zylinderschraube M5x20	screw	vis	tornillo
9	60 35 370		1	Bike-Griffrohr 22x1,5	handlebar	étrier de maintien	tubo de palanca
10	00 18 339		1	Zylinderschraube M5x30	screw	vis	tornillo
11	60 73 567		1	Griffhälfte für Ø 22 mm	grip half	poignée extérieure	casca
12	00 18 356		2	Linsenschraube 4x20	screw	vis	tornillo
13	60 73 568		1	Griffhälfte für Ø 22 mm	grip half	poignée intérieure	casca
14	00 20 131		2	Sechskantmutter M5 EN 27040	nut	écrou	tuerca
15	60 73 570		1	Griffhälfte für Ø 22 mm	grip half	poignée intérieure	casca
16	00 18 356		3	Linsenschraube 4x20	screw	vis	tornillo
17	00 73 389		1	Kontaktfeder	contact spring	ressort de contact	resorte
18	00 73 388		1	Kontaktfeder	contact spring	ressort de contact	resorte
19	00 73 387		1	Schenkelfeder 1,3x6, Schieber	spring	ressort d'interrupteur	muelle
20	00 73 386		1	Schenkelfeder 1x8, Gashebel	spring	ressort d'interrupteur	muelle
21	60 73 573		1	Gashebel	throttle lever	levier de gaz	palanca de gas
22	00 35 158		1	Sicherungsscheibe 4,5x0,3	washer	rondelle	arandela
23	60 73 572		1	Schieber	slide	tiroir	valvula
24	60 73 569		1	Griffhälfte für Ø 22 mm	grip half	poignée extérieure	casca
25	60 73 571		1	Sicherungshebel	safety lever	levier de sécurité	palanca
26	00 18 339		1	Zylinderschraube M5x30	screw	vis	tornillo
27	50 74 100		1	Bowdenzughalter, Ø 22 mm	bowden cable support	collier de serrage	soporte de cable bowden
28	00 21 235		1	Vierkantmutter M5	nut	écrou	tuerca
29	00 84 685		2	Kurzschluß-Massekabel, 1115 mm	ground cable	câble masse	cable de masa
30	00 64 415 R +		1	Schlauch 8,5x36	tube	tuyau	tubo
31	60 74 527		2	Bowdenzughalter, Ø 24 mm	bowden cable support	collier de serrage	soporte de cable bowden
32	28 00 342		1	Bowdenzug, Gas	bowden cable, gas	câble bowden, gaz	cable bowden
33	68 00 312		1	Gasgriff, komplett	throttle grip, compl.	poignée acc., compl.	acelerador

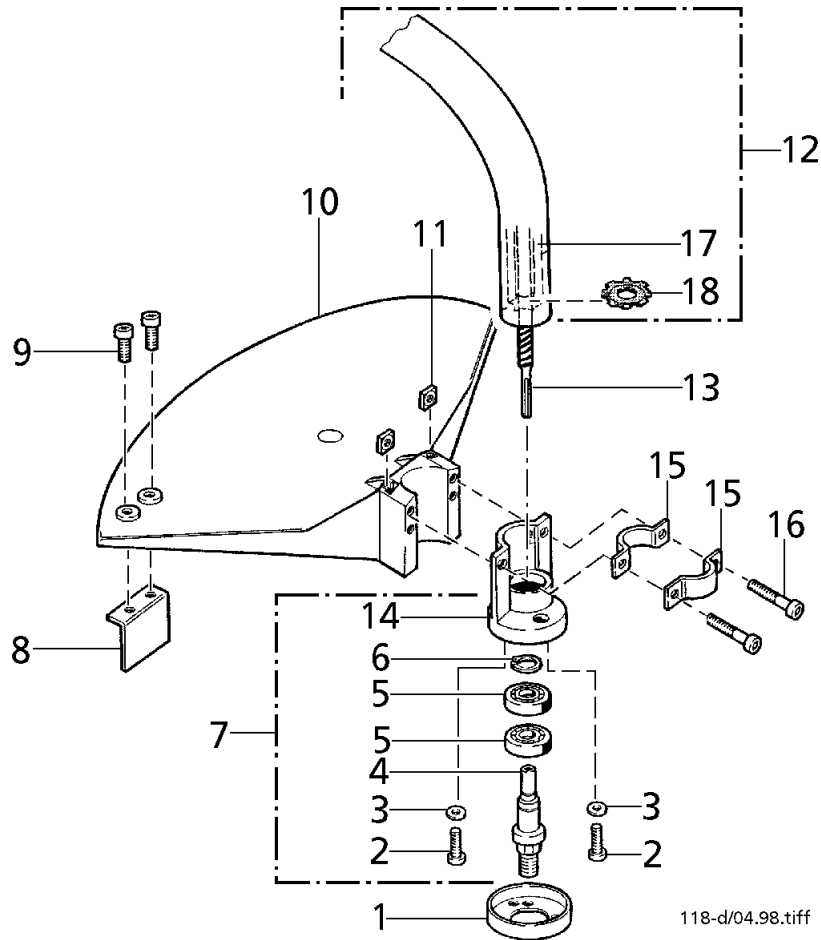

118-d/04.98.tiff

Bild-Nr. Pos.-No. Pos.-No.	Bestell-Nr. Order-No. No. de Cde. Ref.-Nr.	Modell Type Modèle Modelo	Menge Quantity Nombres Cantidad	Schaftrohr/ Schutz	Shaft/ Protection	Tube de transmission/ Protège-lame	Tubo/ Proteccion
1	30 43 432		1	Wickelschutz	anti-clogging device	protecteur d'enroulement	protec. de arrollamiento
2	00 18 274		2	Linsenschraube 5x16	screw	vis	tornillo
3	00 72 140		2	Tellerfeder 12x5,2x0,5 DIN 2093A	spring washer	rondelle ressort	resorte
4	30 31 314		1	Welle M10x1,25x75	shaft	arbre	arbol
5	00 50 173		2	Rillenkugellager 28x12x8	ball bearing	roulement à billes	cojinete de bolas
6	00 55 134		1	Sicherungsring 12x1,0 DIN 471A	circlip	circlip	anillo de seguridad
7	21 00 535		1	Gehäuse (enth.:	housing (incl.:	carter (incl.:	carter (incl.:
(2)	00 18 274			Linsenschraube 5x16	screw	vis	tornillo
(3)	00 72 140			Tellerfeder 12x5,2x0,5 DIN 2093A	spring washer	rondelle plat	resorte
(4)	30 31 314			Welle	shaft	arbre	arbol
(5)	00 50 173			Rillenkugellager 28x12x8	ball bearing	roulement à billes	cojinete de bolas
(6)	00 55 134			Sicherungsring 12x1,0 DIN 471A	circlip	circlip	anillo de seguridad
(14)	60 73 583			Gehäuse	housing)	carter)	carter)
8	69 00 721		1	Messer, Fadenbegrenzung	knife	couteau	cuchilla
9	00 18 338		2	Zylinderschraube M5x16	screw	vis	tornillo
10	60 73 589		1	Schutz	protection	protection	proteccion
11	00 21 241		2	Vierkantsmutter M5	nut	écrou	tuerca
12	63 00 250		1	Schaftrohr, gebogen, inkl. Profilstange	shaft tube	tube	tubo
13	60 35 342		1	Antriebswelle, flexibel	flex. shaft	arbre flexible	eje
14	60 73 583		1	Gehäuse	housing	carter	carter
15	60 43 423		2	Schelle 24x28	clamp	collier de serrage	abrazadera
16	00 18 339		2	Zylinderschraube M5x30	screw	vis	tornillo
17	00 83 147		1	Fett, MOBIL Temp 78	grease MOBIL Temp 78	graisse MOBIL Temp 78	grasa MOBIL Temp 78
18	00 55 286 +		1	Zackenring 22	toothed ring	bague dentée	anillo dentada

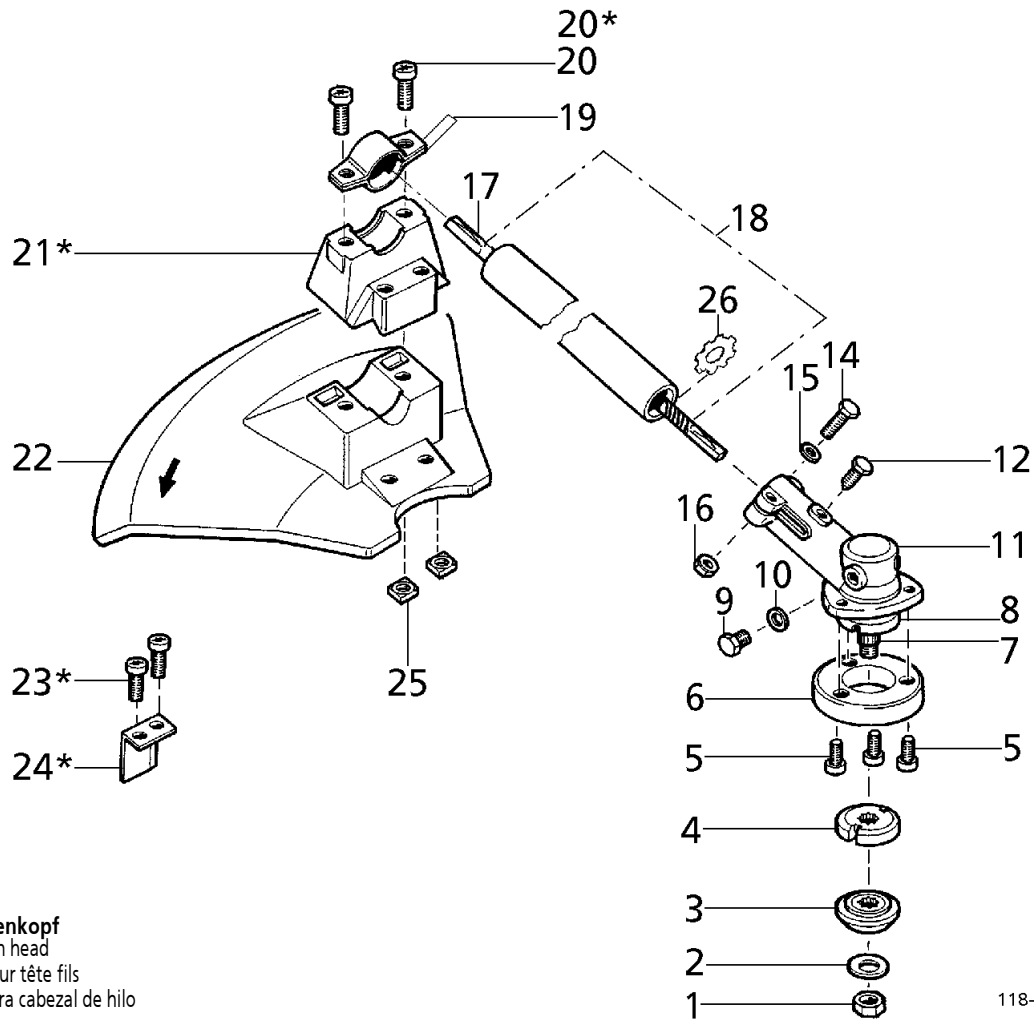

* nur bei Fadenkopf
 * only for Nylon head
 * seulement pour tête fils
 * solamente para cabezal de hilo

118-e/04.98.tiff

Bild-Nr. Pos.-No. Pos.-No.	Bestell-Nr. Order-No. No. de Cde. Ref.-Nr.	Modell Type Modèle Modelo	Menge Quantity Nombres Cantidad	Getriebe/ Schutz	Gear unit/ Protection	Transmission/ Protection	Transmission/ Proteccion
1	00 20 223		1	Sechskantmutter M10x1,25 DIN 8673	nut	écrou	tuerca
2	00 72 169		1	Tellerfeder 10,2x23x1,25 DIN 2093	spring washer	rondelle ressort	resorte
3	30 31 998		1	Druckscheibe 12x20/35x9 Ø 20 mm	washer	rondelle	disco
3	30 31 969		1	Druckstück 25,4 Ø 25,4 mm	pressure part	pièce de pression	pieza de presion
4	30 31 999		1	Druckstück 12x20/35x8 Ø 20 mm	pressure part	pièce de pression	pieza de presion
4	30 31 192		1	Druckstück 25,4 Ø 25,4 mm	pressure part	pièce de pression	pieza de presion
5	00 18 335		3	Zylinderschraube M5x12	screw	vis	tornillo
6	20 74 998		1	Wickelschutz	anti-clogging device	protecteur d'enroulement	protec. de arrollamiento
7	06 10 436		1	Distanzring	spacer	bague à distance	anillo distanciador
8	06 10 438		1	Wellendichtring 17x32x8	oil seal	joint spil	retén
9	00 12 140		1	Sechskantschraube M8x10 DIN 933	screw	vis	tornillo
10	00 61 150		1	Dichtungsring 8x14x1,5 DIN 7603C	gasket	joint plat	empaque
11	00 83 129		-	Fett, FIBRAX EP 37, 20g	grease FIBRAX EP 37	graisse FIBRAX EP 37	grasa FIBRAX EP 37
12	30 00 215		1	Getriebe, Mini Gears	gear	engrenage	engranaje
13	06 10 432		1	Zylinderschraube M5x8	screw	vis	tornillo
14	00 12 194		1	Sechskantschraube M5x40 DIN 933	screw	vis	tornillo
15	00 30 108		1	Scheibe 5,3 DIN 125B	washer	rondelle	arandela
16	00 28 110		1	Sechskantmutter M5 DIN 980	nut	écrou	tuerca
17	60 35 396		1	Antriebswelle, flexibel	flexible drive shaft	arbre	arbol
18	63 00 251		1	Schaftrohr 24x1x1500 (enth.: Fett, MOBIL TEMP 78, 15g Schaftrohr 24x1x1500 inkl. Profilstange)	shaft tube (incl.: grease, MOBIL TEMP 78 shaft tube)	tube (incl.: graisse, MOBIL TEMP 78 arbre)	tubo (incl.: grasa, MOBIL TEMP 78 arbol)
-							
19	60 43 438		2	Schelle, Ø 24 mm	clamp	collier de serrage	abrazadera
19*	00 18 338		2	Zylinderschraube M5x25	screw	vis	tornillo
20*	00 18 378		2	Zylinderschraube M5x55	screw	vis	tornillo
21	60 74 973		1	Zwischenstück	intermediate piece	pièce intermédiaire	pieza intermedia
22*	60 73 618		1	Schutz	protection	protection	proteccion
23*	00 18 338		2	Zylinderschraube M5x25	screw	vis	tornillo
24	69 00 721		1	Fadenbegrenzungsmesser	knife	couteau	cuchilla
25	00 21 241		2	Vierkantmutter M5	nut	écrou	tuerca
26	00 55 286 +		1	Zackenring 22	toothed ring	bague dentée	anillo dentada

118 / 119 L

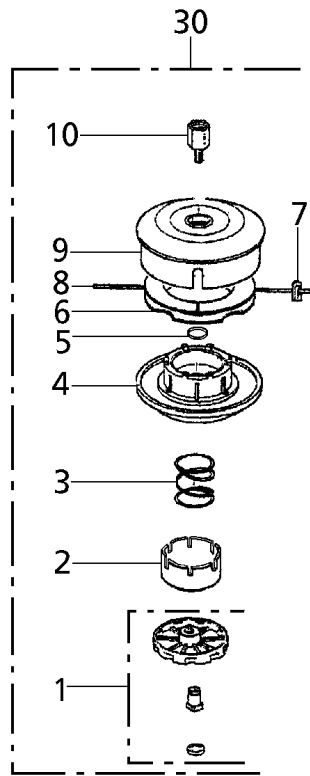

119 B

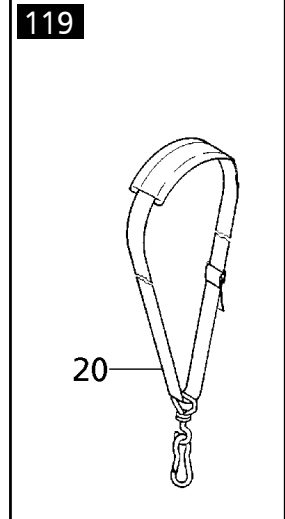
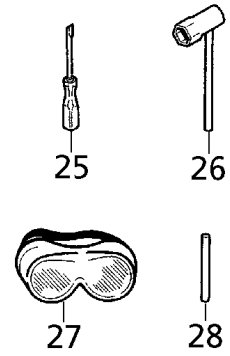
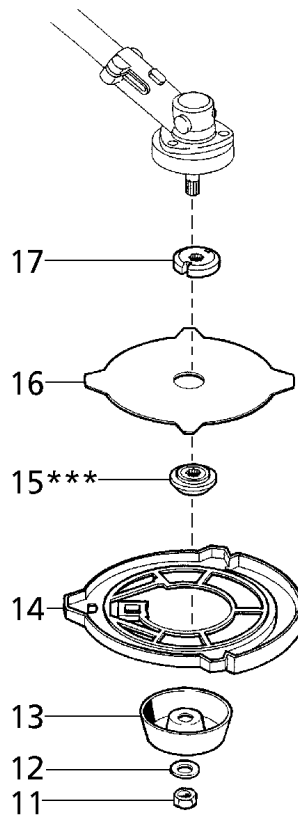

118-f/04.98.tiff

*** nicht bei Fadenkopf
 *** not with Nylon head
 *** ne pas avec tête fils
 *** no para cabezal de hilo

Bild-Nr. Pos.-No. Pos.-No.	Bestell-Nr. Order-No. No. de Cde. Ref.-Nr.	Modell Type Modèle Modelo	Menge Quantity Nombres Cantidad	Werkzeug/ Serienrüstung	Tools/ Standard equipment	Outillage/ Equipement de série	Herramientas/ Equipo en serie
1	06 10 454	118	1	Laufsteller, kompl. (enth.: Laufsteller	disc, compl. (incl.: disc	rondelle bombée, compl. (incl.: rondelle bombée	plato, compl. (incl.: plato
-		118		Mutter M8 li	nut	écrou	tuerca
-		118		Verschlußdeckel 18x4)	cover)	capuchon)	capucha)
1	06 10 127	119 L	1	Laufsteller M8, komplett (enth.: Laufsteller	disc, assembly (incl.: disc	rondelle bombée, compl. (incl.: rondelle bombée	plato, compl. (incl.: plato
-		119 L		Mutter M8	nut	écrou	tuerca
-		119 L		Verschlußdeckel 18x4)	cover)	capuchon)	capucha)
2	60 74 978		1	Druckstück	pressure part	pièce de pression	pieza de presion
3	00 70 286		1	Druckfeder 2,2x34x40	spring	ressort	muelle
4	60 74 979		1	Deckel, Fadenkopf	cover of nylon head	couvercle tête fils	tapa de cabezal
5	00 55 134		1	Sicherungsring 12x1 DIN 471	circlip	circlip	anillo de seguridad
6	60 74 982		1	Fadenspule	line coil	bobine fils	bobina de hilo
7	60 31 938		1	Fadenführungsöse	spring guide	guide de fils	guia
8	00 63 184		1	Schneidefaden, 15 m	replacement line	recharge fils	hilo de recambio
9	60 74 983		1	Gehäuse, Fadenkopf	housing nylon head	coque tête fils	carter, cabezal de hilo
10	60 32 689	118	1	Adapter M10x1,25	adapter	adapteur	adaptador
10	06 10 122	119 L	1	Adapter M10x1,25	adapter	adapteur	adaptador
11	00 20 223	119 B	1	Sechskantmutter M10x1,25 DIN 8673	nut	écrou	tuerca
12	00 72 169	119 B	1	Tellerfeder 10,2x23x1,25 DIN 2093	spring washer	rondelle ressort	resorte
13	30 43 427	119 B	1	Laufsteller	disc	rondelle bombée	plato
14	60 73 534	119 B	1	Transportschutz	transport protection	protection transport	proteccion transporte
15***	33 00 192	119 B	1	Distanzscheibe (enthält: Distanzring 25, 1x20x3	washer (incl.: spacer	rondelle (incl.: bague à distance	arandela (incl.: espaciador
	00 33 368	119 B	1	Druckscheibe 12x20/35x9	washer	rondelle de pression	disco
	30 31 998	119 B	1	Druckstück 25,4)	pressure part)	pièce de pression)	pieza de presion)
	69 00 706	119 B	1	Grasschneideblatt 230x20, 4 Zähne	grass cutt. blade 4-T	lame herbe, 4-dents	hoja de corte, 4 dientes
16	30 31 999	119 B	1	Druckstück 12x20/35x8	pressure part	pièce de pression	pieza de presion
17	33 00 192	119 B	1	Druckstück 25,4	pressure part	pièce de pression	pieza de presion
20	69 00 924	119	1	Tragegurt	carrying strap	bretelle	cinturon portador
25	00 80 494		1	Schraubendreher	screw-driver	tournevis	destornillador
26	00 80 509		1	Kombischlüssel SW19/T25	combi wrench SW19/T25	clef combi SW19/T25	llave combi SW19/T25
27	69 00 691		1	Schutzbrille	safety goggles	lunettes de protection	gafas protectoras
28	00 80 496	118	1	Montagestift 6x80	locking pin	goupille de montage	perno
28	00 80 514	119	1	Montagestift, 5 mm	locking pin	goupille de montage	perno
30	69 00 700	118	1	Fadenkopf, halbautom., kompl.	semi-autom. nylon head	tête fils semi-autom.	cabezal de hilo semi-autom.
30	69 00 833	119 L	1	Fadenkopf, halbautom., kompl.	semi-autom. nylon head	tête fils semi-autom.	cabezal de hilo semi-autom.



Bild-Nr. Pos.-No. Pos.-No. Pos.-No.	Bestell-Nr. Order-No. No. de Cde. Ref.-Nr.	Modell Type Modèle Modelo	Menge Quantity Nombres Cantidad	Zubehör	Accessories	Accessoires	Accesorios
1	69 00 892	119	1	Fadenkopf, manuell, komplett	manual nylon head	tête fils, manuels	cabezal de hilo
2	06 10 121	119	1	Adapter M10x1,25L	adapter	adapteur	adaptador
3	60 74 996	119	1	Gehäuse, Fadenkopf	housing nylon head	coque tête fils	carter, cabezal de hilo
4	60 31 992	119	1	Fadenführungsöse	line guide	guide de fils	guia
5	00 63 184	119	1	Schneidfaden, 15 m	replacement line	recharge fils	hilo de recambio
6	60 74 987	119	1	Deckel, Fadenkopf	cover of nylon head	couvercle tête fils	tapa de cabezal
7	00 70 284	119	1	Druckfeder 2x28x30	spring	ressort	muelle
8	00 28 151	119	1	Flügelmutter M16	nut	écrou	tuerca
10	69 00 706	119	1	Grasschneideblatt, 4-zählig Ø 230 mm	mowing blade, 4-teeth	lame herbe, 4-couteaux	disco de corte, 4-dientes
11	69 00 693	119	1	Grasschneideblatt, 8-zählig Ø 230 mm	mowing blade, 8-teeth	lame herbe, 8-couteaux	disco de corte, 8-dientes
12	69 00 660	119	1	Mähzscheibe, Rototrim	Rototrim mowing blade	lame, Rototrim	disco de corte, Rototrim
-	06 10 444	1	1	Messer für Rototrim	knife for Rototrim	couteau, Rototrim	cuchillo para sistema Rototrim
13	69 00 944	118	1	Fadenkopf, M10x1,25, manuell	nylon head, manual	tête fils, manuels	cabezal de hilo, manual
13	69 00 836	119	1	Fadenkopf, M10x1,25, manuell	nylon head, manual	tête fils, manuels	cabezal de hilo, manual
14	69 00 833	119 B	1	Fadenkopf, M10x1,25, halbautom.	nylon head, semi-autom.	tête fils, semi-autom.	cabezal de hilo, semi-autom.
15	60 74 584	118	1	Grasschneideblatt, 3-zählig Ø 225 mm	mowing blade, 3-teeth	lame herbe, 3-couteaux	disco de corte, 3-dientes
16	69 00 722	118	1	Unkraut-Flexscheibe Ø 230 mm	weed flex blade	lame nyl.mauv.herbes	disco de maleza
18***	30 43 427	1	1	Lauffeller	nut protector	disque de glissement	plato motriz
20	63 00 300	119	1	Doppelschultergurt	harness semi-pro	harnais semi-pro	cinturon portador
22	63 00 331	118	1	Tragegurt, kompl.	carrying strap, compl.	bretelle, compl.	cinturon portador, compl.

Bestell-Nr. Order-No. No. de Cde. Ref.-Nr.	Menge Quantity Nombres Cantidad	Seite page page pagina	Bestell-Nr. Order-No. No. de Cde. Ref.-Nr.	Menge Quantity Nombres Cantidad	Seite page page pagina	Bestell-Nr. Order-No. No. de Cde. Ref.-Nr.	Menge Quantity Nombres Cantidad	Seite page page pagina	Bestell-Nr. Order-No. No. de Cde. Ref.-Nr.	Menge Quantity Nombres Cantidad	Seite page page pagina
00 10 182	2	6	00 50 173	2	8	06 10 454	1	10	35 00 424	1	4
00 12 140	1	9	00 50 173		8	20 00 453	1	4	50 74 100	1	7
00 12 194	1	9	00 55 103	1	4	20 12 876	1	4	60 12 836	1	7
00 12 376	1	7	00 55 134	1	8	20 42 764	1	4	60 12 837	1	7
00 15 289	2	5	00 55 134		8	20 42 839	1	4	60 12 843	1	7
00 18 274	1	4	00 55 134	1	10	20 43 998	1	5	60 31 938	1	10
00 18 274	2	8	00 55 136	1	4	20 48 331	1	4	60 31 992	1	11
00 18 274		8	00 55 286 +	1	8	20 48 331		4	60 32 689	1	10
00 18 286	2	4	00 55 286 +	1	9	20 48 363	1	5	60 35 342	1	8
00 18 291	3	4	00 61 150	1	9	20 61 489	1	4	60 35 370	1	7
00 18 291		4	00 61 360	1	5	20 61 491	1	4	60 35 396	1	9
00 18 333	2	5	00 62 309	1	5	20 61 497	1	4	60 35 975	1	6
00 18 335	3	9	00 63 170 +	1	4	20 63 306	1	4	60 43 423	2	8
00 18 337	2	7	00 63 184	1	10	20 63 306		4	60 43 438	2	6
00 18 337	2	7	00 63 184	1	11	20 73 602	1	4	60 43 438	2	9
00 18 338	1	4	00 63 195	1	4	20 73 664	1	4	60 63 331	1	6
00 18 338	2	6	00 64 300	1	5	20 74 569	1	4	60 63 332	1	5
00 18 338	2	8	00 64 415 R +	1	6	20 74 905	1	4	60 73 534	1	10
00 18 338	2	9	00 64 415 R +	1	7	20 74 911	1	5	60 73 567	1	7
00 18 338	2	9	00 66 457	1	4	20 74 912	1	5	60 73 568	1	7
00 18 339	1	7	00 69 890	1	4	20 74 931 +	1	6	60 73 569	1	7
00 18 339	1	7	00 70 258	2	4	20 74 932 +	1	6	60 73 570	1	7
00 18 339	2	8	00 70 284	1	11	20 74 945	1	6	60 73 571	1	7
00 18 354	1	4	00 70 286	1	10	20 74 957	1	4	60 73 572	1	7
00 18 355	1	4	00 72 120	1	4	20 74 966	1	5	60 73 573	1	7
00 18 355	3	4	00 72 120	1	4	20 74 967	1	4	60 73 583		8
00 18 355	2	4	00 72 140	1	4	20 74 968	1	4	60 73 583	1	8
00 18 356	2	7	00 72 140	2	5	20 74 971	1	4	60 73 584	1	6
00 18 356	3	7	00 72 140	2	8	20 74 972	1	4	60 73 589	1	8
00 18 357 +	2	6	00 72 140		8	20 74 998	1	9	60 73 618	1	9
00 18 363	4	4	00 72 169	1	9	21 00 535	1	8	60 74 527	2	7
00 18 363	3	4	00 72 169	1	10	21 00 596	1	4	60 74 584	1	11
00 18 370	2	4	00 73 351	1	5	23 00 527 +	1	5	60 74 973	1	9
00 18 378	2	9	00 73 374	1	5	23 00 740	1	4	60 74 974	1	4
00 18 389	2	6	00 73 386	1	7	23 00 741	1	5	60 74 978	1	10
00 18 401	2	5	00 73 387	1	7	23 00 743	1	5	60 74 979	1	10
00 18 402	4	4	00 73 388	1	7	23 00 787 *+	1	4	60 74 982	1	10
00 18 402	2	4	00 73 389	1	7	24 00 293	1	4	60 74 983	1	10
00 18 403	4	4	00 73 401	1	4	25 00 701	1	4	60 74 987	1	11
00 18 405	1	4	00 75 135	1	4	26 00 285	1	4	60 74 996	1	11
00 20 131	2	7	00 80 494	1	10	27 00 285	1	5	61 00 377	1	4
00 20 160	2	6	00 80 496	1	10	27 00 363	1	5	63 00 250	1	8
00 20 223	1	9	00 80 509	1	10	27 00 367	1	5	63 00 251	1	9
00 20 223	1	10	00 80 514	1	10	27 00 368	1	5	63 00 300	1	11
00 21 235	2	4	00 83 129	-	9	27 00 383 *+	1	5	63 00 331	1	11
00 21 235	1	7	00 83 147	1	8	28 00 342	1	7	68 00 264	1	7
00 21 241	1	4	00 84 672	1	5	28 00 345	1	6	68 00 306	1	6
00 21 241	1	4	00 84 673	2	6	30 00 215	1	9	68 00 312	1	7
00 21 241	2	6	00 84 685	2	7	30 31 192	1	10	68 00 328	1	6
00 21 241	2	8	00 94 274	1	4	30 31 314	1	8	69 00 660	1	11
00 21 241	2	9	00 94 274	1	4	30 31 314		8	69 00 691	1	10
00 28 110	2	6	05 10 918	1	5	30 31 969	1	9	69 00 693	1	11
00 28 110	1	9	05 10 920	1	5	30 31 969	1	10	69 00 700	1	10
00 28 149	2	4	05 10 921	1	4	30 31 998	1	9	69 00 706	1	10
00 28 151	1	11	05 10 974	1	5	30 31 998	1	10	69 00 706	1	11
00 30 108	1	9	05 10 975	1	5	30 31 999	1	9	69 00 721	1	8
00 30 128	1	7	06 10 121	1	11	30 31 999	1	10	69 00 721	1	9
00 31 601	1	4	06 10 122	1	10	30 43 427	1	10	69 00 722	1	11
00 31 607	1	4	06 10 127	1	10	30 43 427	1	11	69 00 833	1	10
00 33 368	1	10	06 10 432	1	9	30 43 432	1	8	69 00 833	1	11
00 33 371	2	5	06 10 436	1	9	33 00 192	1	9	69 00 836	1	11
00 33 372	1	4	06 10 438	1	9	33 00 192	1	10	69 00 892	1	11
00 35 158	1	7	06 10 444	1	11	35 00 423	1	4	69 00 924	1	10
									69 00 944	1	11

Allgemeine Richtlinien für die Bestellung von Original SOLO Ersatzteilen: Voraussetzung für eine reibungslose Erledigung sind folgende Angaben:

1. Ersatzteil-Bestellnummer
2. Gewünschte Anzahl
3. Typenbezeichnung des Geräts

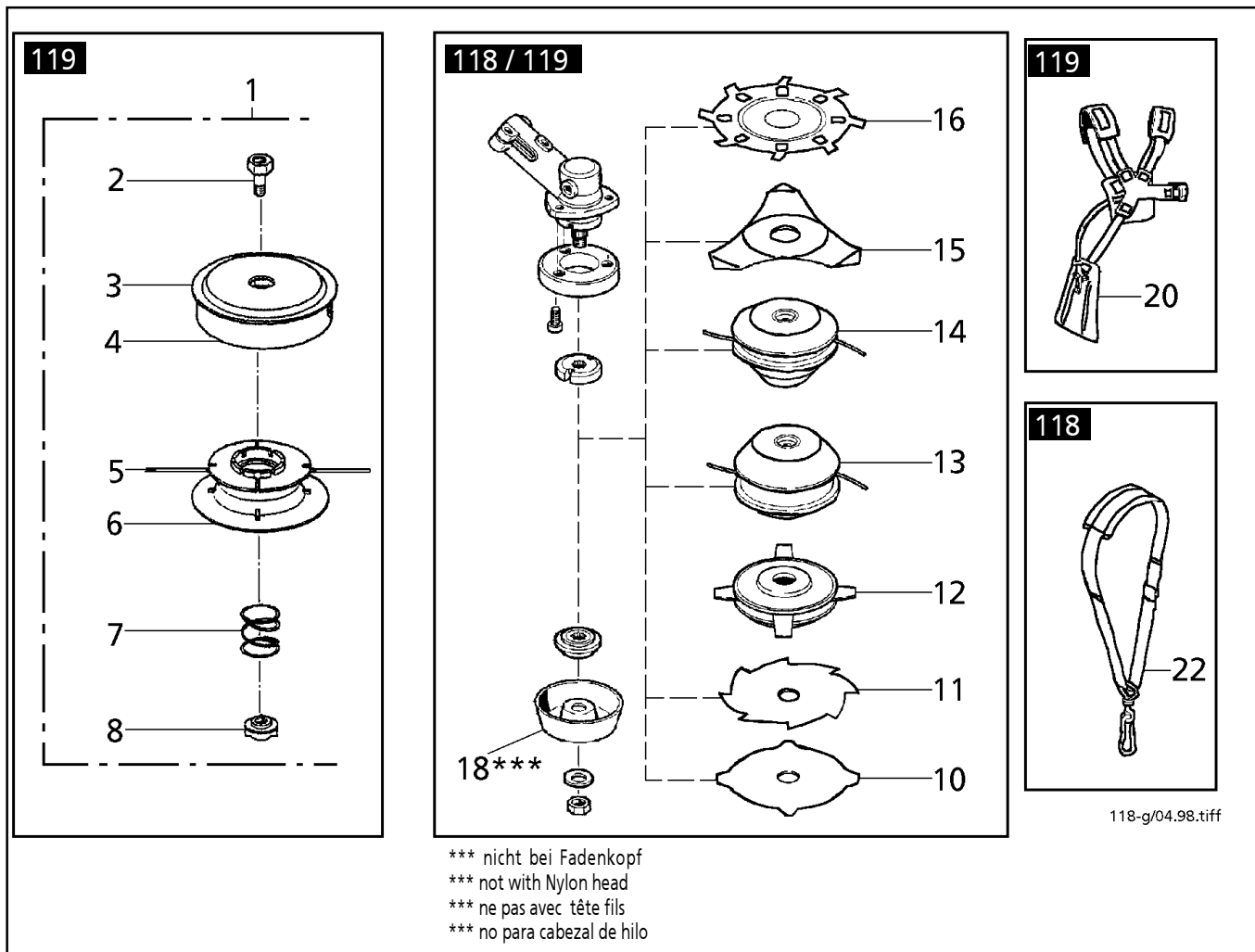
Diese Ersatzteilliste ist für die Lieferung und Ausstattung von SOLO Erzeugnissen unverbindlich.

Im Interesse der technischen Weiterentwicklung bleiben Konstruktionsänderungen vorbehalten.

General Directions for Ordering Original SOLO Spare Parts: Spare parts orders are to be placed with the SOLO Sales Branch or SOLO Distributor: For correct and diligent processing of your order, please give the following information:

1. Spare Part number
2. Quantity
3. Model and serial number
4. Shipping instructions

Delivery is made in accordance with our general sales and delivery conditions. This spare parts list is non-committal for us with regard to delivery and layout of SOLO products. In favour of technical improvements, design modifications are subject to change without notice.

Directives générales pour les commandes de pièces de rechange d'origine SOLO: Il est indispensable de préciser dans toutes les commandes de pièces:

1. - le numéro de référence de la pièce
2. - la quantité
3. - le type de la machine
4. - le mode d'expédition

Les livraisons sont effectuées dans le cadre de nos conditions générales de vente. Toutes modifications réservées.

Directivas Generales de pedido de la firma SOLO: Por adelantado de un arreglo sin dificultades necesitamos siguientes indicaciones:

1. Número de repuesto
 2. Numero de cantidad
 3. Modelo y número de serial
 4. Instrucción de Envío
- Este lista de repuestos no es obligatoria para los envíos y/o forma de equipo de los productos SOLO. En el interés del constante desarrollo debemos reservarnos el derecho de cambios.