

**OPERATING
INSTRUCTIONS**

•

**MAINTENANCE
GUIDE**

•

**SAFETY
WARNINGS**

•

PARTS LIST

TARGET®

**Quickie
Models**

45/12, 45/14

52/12, 52/14

65/12, 65/14

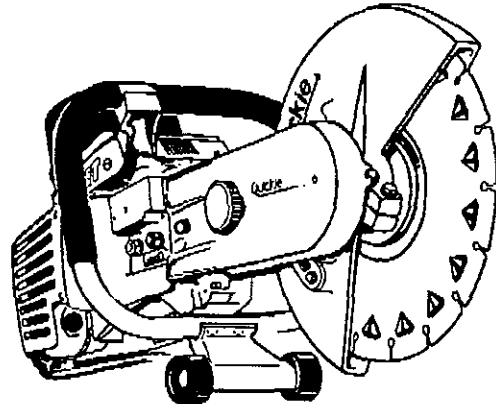

February, 1993

TARGET®

17400 West 119th Street
Olathe, KS 66061
Customer Service 800-288-5040
Corp. Office 913-928-1000
Cust. Service FAX 800-825-0028
Corp. Office FAX 913-438-7951
Int'l. Customer Service 913-928-1300
Int'l. FAX 913-438-7938
Internet <http://www.targetdbi.com>

CONTROLS AND FEATURES

"A" (blade side of saw)

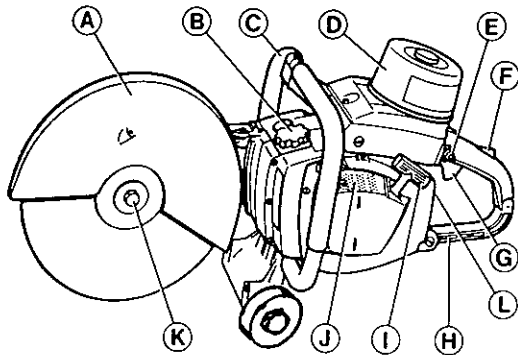

- A. Blade Guard
- B. Fuel Tank Cap
- C. Front Handle
- D. Filter Cover
- E. Throttle Trigger Lock
- F. Safety Trigger
- G. Throttle Trigger
- H. Bottom Frame
- I. Starter Handle
- J. Cooling Air Screen
- K. Blade Shaft Flange and Nut
- L. Ignition Switch

"B" (belt guard side of saw)

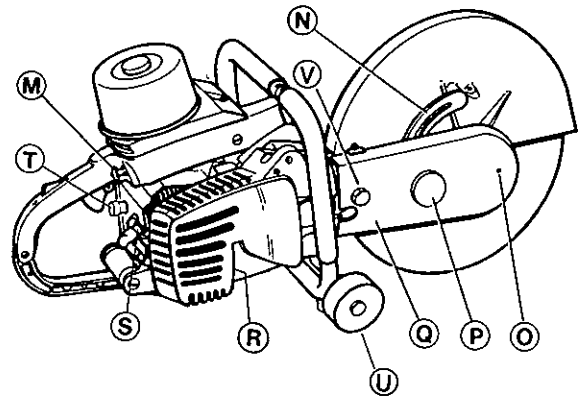

- M. Choke Button
- N. Blade Guard Adjusting Track
- O. Lock Pin Hole (for easy blade removal)
- P. Lock Knob (for blade guard adjustment control)
- Q. Belt Guard
- R. Muffler
- S. Spark Plug
- T. Decompression Valve
- U. Wheel Kit
- V. Belt-Tensioning Bolt

SPECIFICATIONS

		45/12	45/14	52/12	52/14	65/12	65/14
WEIGHT		26-1/2 lbs.	27 lbs.	28-1/4 Lbs.	28-3/4 lbs.	28-1/4 lbs.	28-3/4 lbs.
DIMENSIONS	LENGTH	32"	33"	33-1/4"	34-1/4"	33-1/2"	34-1/4"
	HEIGHT	13-1/4"	13-1/4"	13-3/4"	13-1/2"	13-1/2"	13-1/2"
	WIDTH	14-3/4"	14-3/4"	15-1/2"	16-1/4"	15-1/4"	16-1/4"
MAX. DEPTH OF CUT		4"	5"	4"	5"	4"	5"
MAX. BLADE CAPACITY		12"	14"	12"	14"	12"	14"
DISPLACEMENT CU. IN.		4.4	4.4	5.0	5.0	6.0	6.0
IGNITION		CAPACITOR DISCHARGE IGNITION					
SPARK PLUG		CHAMPION RCJ7Y, CJ7Y, CJ8					
SPARK PLUG GAP		.030					
FUEL TANK CAP. PINTS		1.7	1.7	2	2	2	2

SAFETY WARNINGS - DO'S AND DON'TS

Everyone who uses this gasoline powered hand saw should read this manual and be familiar with the safety warnings. Failure to obey a safety warning may result in injury to yourself or others.

DO'S

1. Do use abrasive blades marked with a maximum operating speed of at least 5400 R.P.M. on 14" and 6200 R.P.M. on 12".
2. Do use high speed reinforced abrasive blades marked 1/8" thick (minimum) with 1" hole.
3. Do use abrasive blades marked for use on gasoline powered, hand-held, portable abrasive cutting-off machines.
4. Do use Interlok® diamond blades for WET cutting or Dri Disc™ diamond blades for DRY cutting on masonry and concrete.
5. Do always use safety footwear, snugfitting clothing, safety goggles, and hearing and head protection devices while using a cutting-off machine. (Fig. 1)
6. Do use caution when handling fuel.
7. Do move the cutting-off machine at least 10 feet from the fueling point before starting engine and make sure the gas caps on the machine and the fuel can are properly tightened.
8. Do always hold the machine with both hands when the engine is running. Use a firm grip with thumbs and fingers encircling the handles. (Fig. 2)
9. Do keep all parts of your body away from the cutting-off blade when the engine is running.
10. Do make sure blade is not contacting anything before starting the engine.
11. Do always carry the machine with the engine stopped and the muffler away from your body. (Fig. 3)
12. Do always shut off the engine before setting the machine down.
13. Do keep the handles dry, clean and free of oil or fuel.
14. Do operate the machine only in well ventilated areas.
15. Do inspect all blades before mounting for possible damage in transit.
16. Do use respiratory protection when dusty conditions exist.

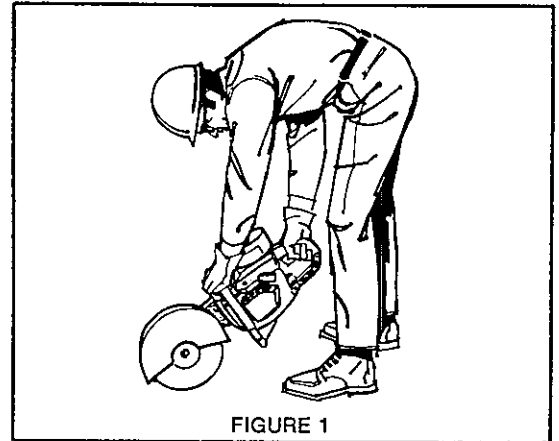

FIGURE 1

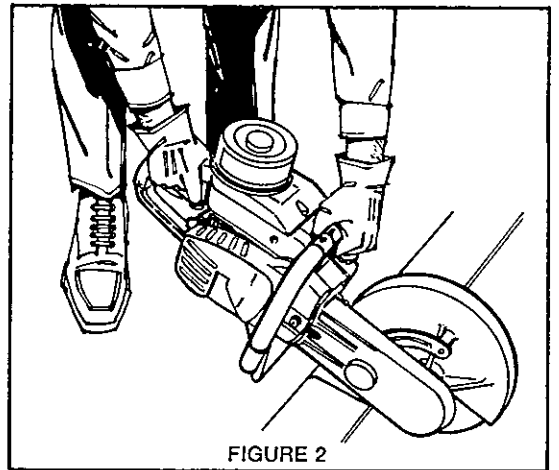

FIGURE 2

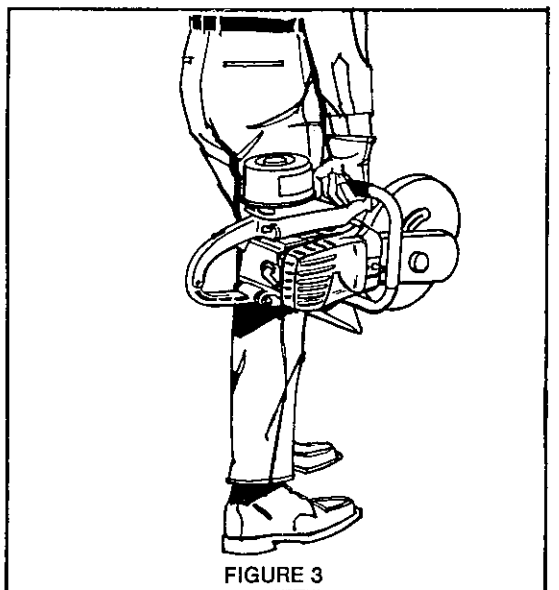

FIGURE 3

DON'TS

1. Don't use abrasive blades that are less than 1/8" thick.
2. Don't use segmented diamond blades unless specifically designed for high speed hand-held saws.
3. Don't operate an abrasive cutting-off machine unless specifically trained to do so.
4. Don't operate a cutting-off machine that is damaged, improperly adjusted, or not completely and securely assembled.
5. Don't transport or store a cutting-off machine with the blade mounted on the machine.
6. Don't cock, jam or wedge the blade in the cut.
7. Don't cause sparks in the vicinity of anything that is flammable.
8. Don't operate the machine without the blade guard in place.
9. Don't start cutting until you have a clear work area and secure footing.
10. Don't allow other persons to be near the machine when starting, refueling, or when cutting.
11. Don't operate any machine when you are tired or fatigued.
12. Don't use an abrasive blade that has been dropped.
13. Don't operate a cutting machine if the blade does not stop rotating when the throttle trigger is released.
14. Don't allow bystanders and animals in the work area. (Fig. 4)
15. Don't grind on the side of a cutting-off blade.
16. Don't exceed the maximum operating speed marked on the blade.
18. Don't use carbide tipped or toothed type blades of any kind.

Everyone who uses this gasoline powered hand-held saw should read this manual and be familiar with the safety warnings. Failure to obey a safety warning may result in injury to yourself or others.



FUEL AND LUBRICATION

ENGINE: Engine life depends on proper fuel mixture -- the right grade of gasoline and the right type of quality oil, both in the proper ratio. Efficient operation and proper lubrication of the engine's internal moving parts depend on this. The internal parts of the saw engine are lubricated solely by the lubricant which is added to the gasoline.

Warning

Gasoline is extremely flammable and highly explosive under certain conditions. Always stop engine, and do not smoke or allow an open flame or spark near the saw when refueling or servicing the fuel system. Always mix in a well ventilated area.

GASOLINE: Use leaded or non-leaded REGULAR gasoline. Premium or high octane gasoline is not recommended. Gasoline containing greater than 10% alcohol is not recommended.

OIL: For best results use Target Quickie Lube (or you may substitute a reputable brand two stroke engine oil).

MIXING: Proper and complete mixing of oil and gasoline is important. Pour about half of the gasoline to be mixed into a clean gasoline container. Add all of the oil required, then stir or shake until thoroughly mixed. Add the balance of the gasoline to make the correct mixture, then stir or shake until permanently blended.

DO NOT MIX DIRECTLY IN FUEL TANK.

NOTE: Your cut-off saw engine has been run-in and adjusted at the factory for optimum performance and fuel economy. To maintain this performance and ensure a long, serviceable engine life, it is recommended that a break-in procedure be observed. For the first tank full of fuel mixture use a richer oil to gasoline ratio, 16:1 (6%); one part reputable brand two-cycle engine oil to 16 parts gasoline. For example 1/2 pint of oil per gallon of gasoline or 60 ml of oil per liter of gasoline.

Break-in mixture is not required when using Target Quickie Lube.

ENGINE LUBRICATION AFTER BREAK-IN: Use one part two cycle motor oil to 24 parts gasoline (4%) or one part Target Quickie Lube oil to 40 parts gasoline (2.5%).

NOTE: Mix your fuel thoroughly and keep clean at all times. Do not mix directly in your saw fuel tank. Be sure to clean the area around the fuel cap with a clean cloth before removing the cap. Do not allow contaminants to enter the fuel tank.

MIXTURE CHARTS

STANDARD MIXTURE 24:1 (4%)					
U.S.A.		IMPERIAL		METRIC	
Fuel	Oil	Fuel	Oil	Fuel	Oil
1 gal.	5.3 oz.	1 gal.	6.6 oz.	5 liter	200 ml.

MIXTURE WITH TARGET QUICKIE LUBE 40:1 (2.5%)					
U.S.A.		IMPERIAL		METRIC	
Fuel	Oil	Fuel	Oil	Fuel	Oil
1 gal.	3.2 oz.	1 gal.	4.0 oz.	5 liter	125 ml.

NOTE: One (1) USA gallon = 128 fluid ounces.
One (1) Imperial gallon = 160 fluid ounces.

SPECIAL SAFETY GAS CAN

A special safety gas can is available through your distributor.

When refueling the engine, carefully follow these instructions.

CAUTION REFUEL ENGINE SAFELY!

DO use Type I with funnel or Type II safety can for gasoline -- See OSHA regulations 1910.106, 1926.152 and 1926.155.

DO refuel slowly to avoid spillage.

DO inspect and make sure all fuel lines are tight and in good condition before refueling engine.

DO tighten fuel tank cap after refueling.

DO wipe engine clean after refueling.

DO NOT refuel a running engine.

DO NOT refuel a hot engine.

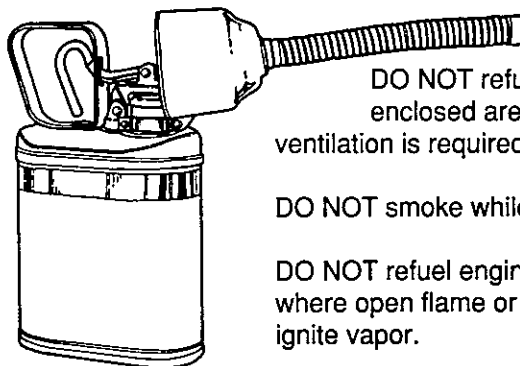

DO NOT refuel engine in enclosed area - adequate ventilation is required.

DO NOT smoke while refueling engine.

DO NOT refuel engine in an area where open flame or sparks can ignite vapor.

FAILURE TO COMPLY COULD RESULT IN SERIOUS BODILY INJURY.

STARTING INSTRUCTIONS

Refer to safety precautions before starting:

1. Fill fuel tank with properly mixed fuel as previously explained.
2. To start the engine, place the saw in a convenient position where it will sit firmly when you pull the starter handle (A-Fig. 5). Place the on-off toggle switch (B-Fig. 5) in the "on" position, pull the choke knob (C-Fig. 5) out. Set the throttle trigger lock (D-Fig. 5) by squeezing the safety trigger (E-Fig. 5) and the throttle trigger (F-Fig. 5); depress the throttle trigger lock and release the throttle trigger. Depress the decompression valve (G-Fig. 5).
3. Hold the handle firmly and place your foot in the bottom frame loop (Fig. 6). Grip the starter handle. Pull the handle slightly until you feel the starter engage, then give a sharp, short, firm pull. Repeat until engine starts. Do not pull starter rope fully out. This action weakens the recoil spring and rope anchor. When the engine starts, allow the starter handle to recoil to its original position. Do not allow handle to snap back.
4. Once the engine has started and requires no further choking, push choke knob in. Release the throttle trigger lock (to insure slow idle) by again squeezing and releasing the throttle trigger.

NOTE: A hot engine should restart without choking. Inadvertent flooding may require 6 to 8 pulls to clear and restart. If, after the above, engine fails to start, a single choking may be necessary.

To stop the saw, place the ignition on-off toggle switch to the "off" position by moving the toggle switch downward.

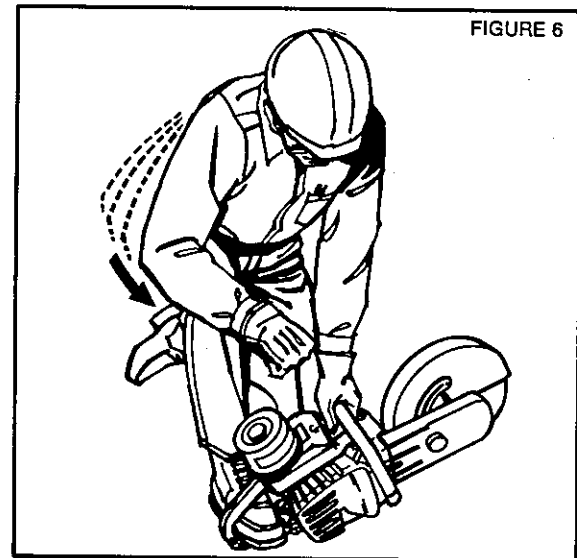
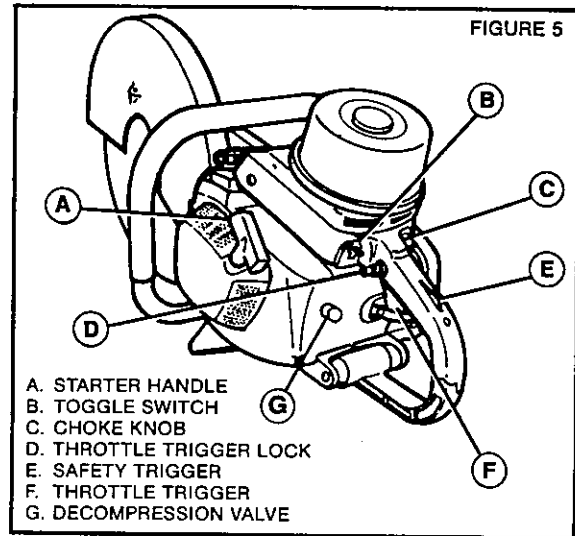

BREAKING IN A NEW ENGINE

Fill with break-in fuel mixture as shown in fuel mixture table. This fuel mixture is recommended for the first tank full. Run the engine at one-third throttle for the first few minutes. (Break-in mixture is not required with Target Quickie Lube, but follow break-in procedures.)

Increase speed to one-half throttle and run a few minutes longer. **NEVER RUN AT FULL THROTTLE EXCEPT UNDER LOAD.**

Begin sawing by making a few small cuts for the first half hour or so.

Do not change carburetor adjustment. It has been factory set for correct engine speed and performance.

During the break-in, frequently check the muffler parts. If the muffler develops a white or gray appearance after a few hours of running, the engine has been running too hot and the fuel mixture has been too lean.

BLADE SELECTION, MOUNTING AND CUTTING



WARNING

DO NOT USE CARBIDE TIPPED OR TOOTHED TYPE BLADES OF ANY KIND. USE OF THESE BLADES MAY RESULT IN INJURY TO YOURSELF OR OTHERS.

There are three types of Target blades available for use on your gasoline powered hand saw, each specially designed for outstanding results on specific materials:

- High Speed reinforced abrasive blades:
 - BLUE blades for cutting metal.
 - RED blades for cutting masonry and concrete materials.
 - GREEN blades for cutting ductile iron and similar materials.
- Interlok® diamond blades for WET cutting on masonry and concrete materials.
- Dri Disc™ diamond blades for DRY cutting on masonry and concrete materials.

These blades are available from your Target distributor. 12" abrasive blades must be at least 1/8" thick with a 1" arbor hole, high speed reinforced with a maximum operating speed of at least 6200 RPM. 14" abrasive blades must be at least 1/8" thick with a 1" arbor hole, high speed reinforced with a maximum operating speed of at least 5400 RPM.



WARNING

DO NOT USE REGULAR MASONRY, CONCRETE/ASPHALT OR METAL CUTTING BLADES EVEN THOUGH THEY ARE REINFORCED. USE OF THESE BLADES MAY RESULT IN INJURY TO YOURSELF OR OTHERS.

The Use of Diamond Blades:

DON'T use conventional wet cutting segmented diamond blades with gasoline powered hand-held saws. Misuse and abuse may cause segment loss and result in personal injury. We recommend Target Interlok® wet cutting and Target Dri Disc™ laser welded DRY cutting diamond blades for your gasoline powered hand-held saws.

Mounting:

Use only blades with 1" mounting hole. Clean mounting surface and be sure blades are properly in place before tightening outer flange. Do not attempt to alter the arbor hole. This will damage the blade and render it unsafe for use.

Blade Shaft Lock Pin Hole:

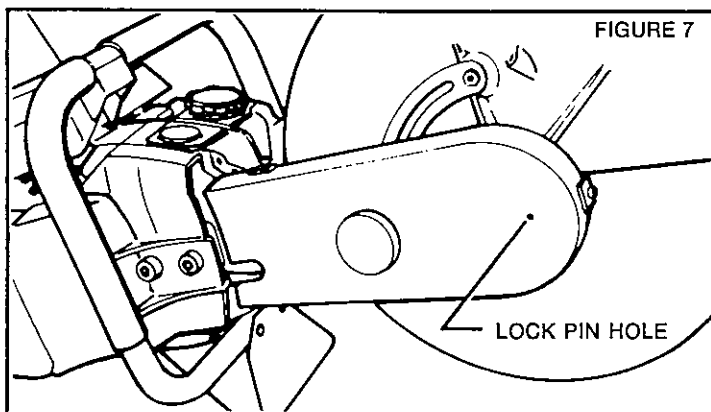

To facilitate blade removal, a lock pin hole is located toward the front of the belt guard (Fig. 7). A 1/4" rod may be inserted into the hole. The blade should be rotated until the rod engages the hole in the pulley. When engaged, push the rod in until it seats into a third hole, located in the bearing housing. This securely locks the blade shaft, and the blade shaft hex locking screw can be easily removed.*

*** CAUTION: Always make certain the rod is engaged in ALL THREE HOLES or pulley and belt guard could be damaged if blade shaft hex locking screw is too tight. Be sure to remove the rod before attempting to restart the saw.**

Cutting:

Read and understand safety instructions before operating saw. Do not operate without safety goggles.

Determine the type cut to be made, then adjust the blade guard accordingly. The blade guard is adjusted by loosening the adjustment knob on the belt guard. Position the blade guard to the desired angle; then re-tighten the control knob securely. When properly positioned, the blade guard will act as a dust deflector, directing the dust away from the operator.

When starting the cut it is advisable to start from a flat surface rather than from the corner of the material.

MACHINE CARE AND MAINTENANCE

Competent persons should be assigned to the inspection and care of the cutting-off machines. Such persons should be fully instructed in the use, care and protection of the machines.

Power Source and Clutching:

The following should be checked before operation:

1. **Engine On/Off Switch** -- must turn engine off when switched to the stop position.
2. **Throttle** -- linkage must be free through full travel and must be set to disengage clutch when throttle is released.
3. **Carburetor** -- idle speed must be set below clutch engagement speed and the maximum regulated speed must not be greater than the blade's maximum rated RPM. Maximum speed is regulated by the high speed needle valve and governor. For proper settings refer to the carburetor section.
4. **Guards and Handles** -- check to see that guards are in place and handles securely fastened to the unit.

Arm:

Before mounting the blade, the arm should be inspected for signs of wear and/or cracking. All mounting devices should be checked for proper tightness.

Belt Guard:

The belt guard should be inspected for signs of wear and/or cracking, and all mounting devices should be checked for proper tightness.

Blade Guard:

The blade guard should be inspected for cracking and other fatigue or structural damage. It should be rotated to insure free movement about the blade-arbor centerline and the locking mechanism should be tested for proper holding.

Blade Mount and Flanges:

The blade mount and flanges should be inspected prior to the installation of the blade for burrs and to verify that the bearing surfaces are flat and run true on the arbor. Threads for clamping the flanges must be in good condition.

Cleaning:

For best performance the engine should be kept clean. Keep the cooling fins and the holes in the dust guard free of any build up of dirt. Clean the cooling fins and dust guard frequently.

Remove the belt guard and clean around the clutch area. Belt and pulleys will wear rapidly if excessive dust builds up.

Air Filter:

This saw features a filtering system (Fig. 8) specially designed for maximum engine protection even under the most severe dusty conditions. It consists of an inner paper filter and an outer foam filter which pre-cleans the air. During masonry cutting or other extremely dusty conditions it may be necessary to clean the filters every 60 minutes of operation. During metal cutting, every two hours or so should be sufficient.

RUNNING THE ENGINE WITHOUT FILTER WILL REDUCE ENGINE PERFORMANCE AND SHORTEN ENGINE LIFE AND VOID WARRANTY.

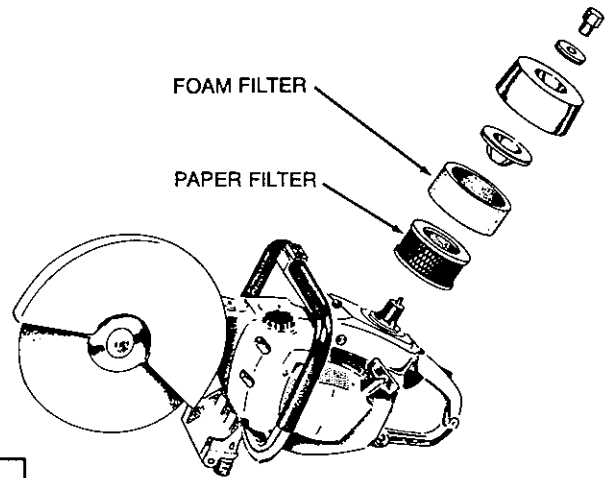

FIGURE 8

Cleaning Air Filter:

1. Remove dust cover.
2. Remove upper filter clamp assembly.
3. Remove foam filter and clean with soap and water.
4. Clean paper filter by gently tapping bottom ring on hard surface. Be careful not to deform or damage filter rim. Do not use compressed air.
5. Replace dirty filters, if necessary.
6. Clean upper and lower gaskets before assembly. Be sure rubber gaskets are glued in place.
7. Replace cover and tighten locking nut firmly.

DO NOT RUN THE ENGINE WITHOUT FILTER ELEMENTS IN PLACE AS DUST AND DIRT IN THE AIR CAN CAUSE RAPID WEAR OF THE PISTON RINGS AND CYLINDER WALL.

Spark Plug:

The spark plug should be cleaned and have its gap adjusted regularly. Spark plug gap is .030. Spark plugs should be Champion RCJ7Y, CJ7Y or CJ8.

Exhaust Port (Muffler):

Loss of power results when the exhaust port opening is clogged. If the engine begins to lose power check the exhaust port and muffler to see if they need cleaning. This is seldom required if the correct oil and gas mixture is used.

1. Remove the screws attaching the muffler to the engine and remove cover.
2. Clean the opening in the muffler. Using a wire brush carefully remove accumulated carbon deposits.
3. Before cleaning the exhaust port, pull the starter handle slowly until the piston covers the exhaust port.

DO NOT USE A METAL SCRAPER OF ANY KIND NEAR THE EXHAUST PORT BECAUSE THE SCRAPER COULD SLIP AND SCRATCH THE PISTON AND RINGS.

4. Scrape the carbon from the exhaust port with a wooden scraper.
5. Blow away the loose carbon or turn the saw with the exhaust port down and shake the carbon particles from the exhaust port.
6. Reinstall the muffler. If the gasket is damaged, install a new one. **NEVER OPERATE THE ENGINE WITH ANY OF THE SHROUDING REMOVED.** Injury to you or others could result. (Fig. 9)

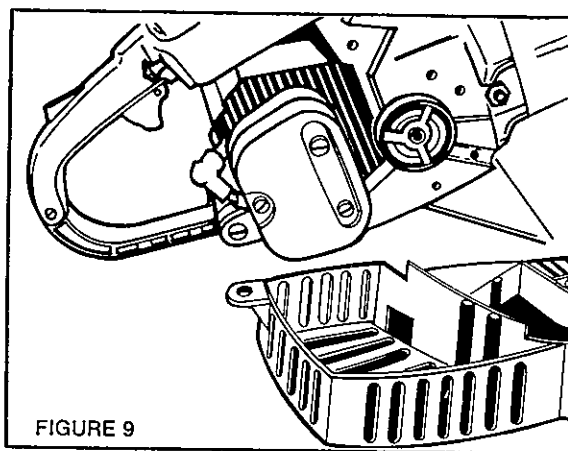

FIGURE 9

Fuel Filter:

Periodically replace the felt filter element located in the fuel tank. This will ensure that an unhindered flow of filtered fuel reaches the carburetor (Fig. 10).

Fan Housing and Cooling Fins:

An air cooled engine must have an unhindered flow of air to maintain proper operating temperatures. The grill in the fan housing and the cooling fins must be kept clean or the engine will overheat. Remove fan housing and scrape dirt and dust from cooling fins. (Fig. 11)

Starter Rope:

Check rope for fraying and replace when frayed.

V-Belt:

Check belts for proper tension. Belt should deflect 3/16" half-way between pulleys with 8 to 9 pound load.

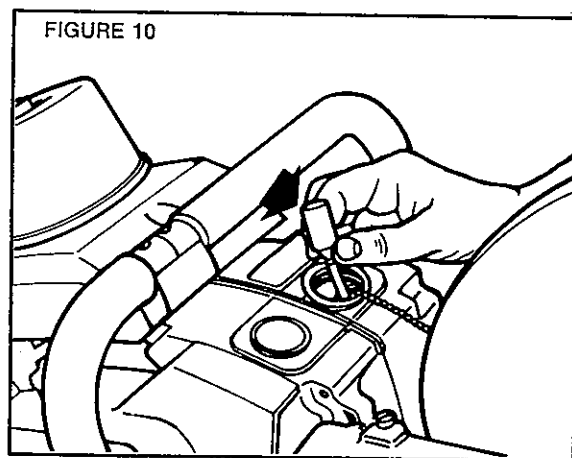

FIGURE 10

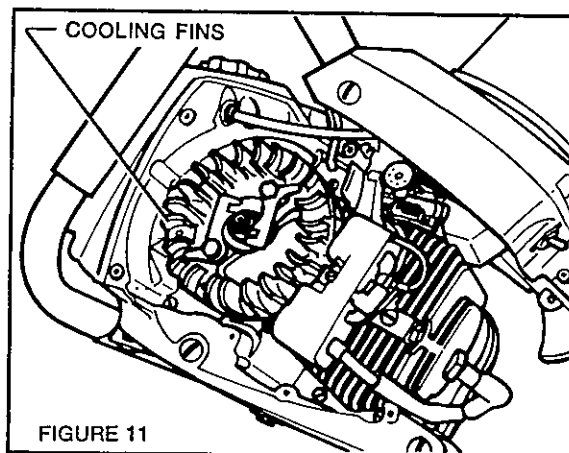
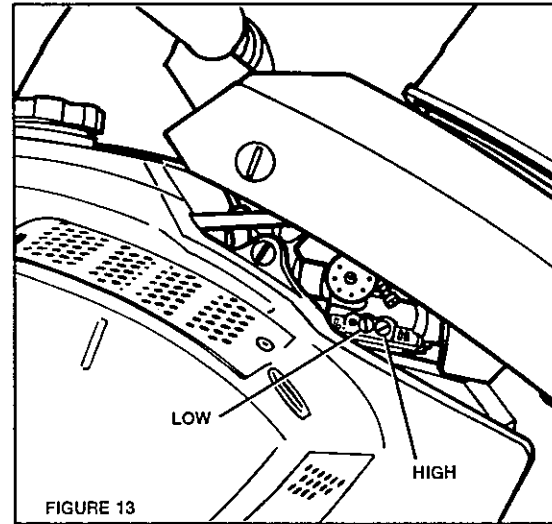

FIGURE 11

Carburetor:

1. Initial carburetor settings: (See Figure 13)

Model	No. of Turns Open
45/12 45/14	Lo 1 Hi 1/4
52/12 52/14	Lo 1 Hi 1/4
65/12 65/14	Lo 1 Hi 1/4



All models use the same model Walbro WJ21B carburetor which has an initial setting at 1 turn open Lo and 1/4 turn open Hi. Total effective high speed mixture setting is between 1/8 to 1/4 turn open. When adjusting the carburetor, avoid jamming the adjustment screw into seat within the carburetor body. To do so will damage the carburetor beyond repair. (See Fig. 12)

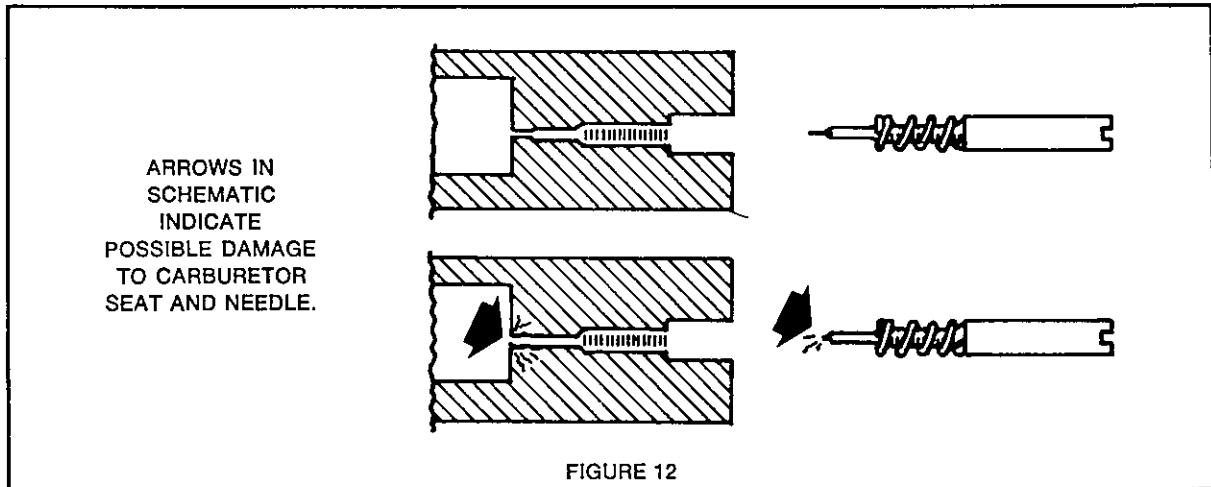

2. Final carburetor settings:

Make final carburetor adjustments with engine warm and running. Adjust idle speed screw so that the engine is idling at just below clutch engagement speed; do not try to make engine idle any slower than this. Adjust idle fuel needle for best engine idle performance, *keeping the mixture as rich as possible* (turn needle out to richen mixture). If necessary, readjust idle speed screw.

Adjust HI-speed fuel needle for best engine performance under cutting load. **CAUTION: Too lean an adjustment of the HI-speed carburetor jet will cause loss of power and inadequate lubrication of the engine.** Adjust to the point where the engine runs smoothly *under load only*. NOTE: Final adjustment of the HI-speed jet should be made only for load condition and maximum power. High speed running while the saw is not under load can be harmful.

Start the saw into the cut and check to see that it runs smoothly and evenly under load. If not, adjust HI-speed jet.

Ignition Module:

The spacing between the ignition module and the flywheel magnet should be 0.010-0.015 inches.

TROUBLESHOOTING

NOTE: ALWAYS CHECK FIRST FOR A DIRTY AIR FILTER

TROUBLE	PROBABLE CAUSE	REMEDY
Engine fails to start.	<p>Fuel tank empty. Engine not choked. Carburetor adjustments. Over-choking. Flooded engine.</p> <p>Spark plug.</p> <p>Ignition Module</p> <p>Plugged or frost covered pickup in fuel tank.</p> <p>Plugged impulse hole in carburetor, misaligned carburetor gasket or reed valve gasket. Frozen gas line or ice in carburetor filter.</p>	<p>Fill with correct fuel mixture. Choke engine. See starting instructions. Open throttle and pull starter until engine fires. Have authorized dealer check carburetor, check for plugged air filter. Remove plug, clean and adjust. Reattach wire and hold metal seat of plug against motor. Pull starter. A blue spark should jump gap between electrodes. (See safety warning on page 4)</p> <div style="display: flex; align-items: center;">  <p style="margin: 0;">Safety Warning</p> </div> <p>When performing this test ensure the absence of fuel in the test area. Gasoline is extremely flammable and highly explosive under certain conditions.</p> <p>If no spark, the trouble is ignition module, shorted wire or switch. Remove, clean or replace. Check for ice, water and dirt in fuel tank. Remove, clean and realign or replace gasket(s). Remove and clean. De-ice additive used in prescribed proportion will counteract this. One teaspoonful to a full tank of fuel. (OMC 2 + 4 Fuel Conditioner)</p>
Engine cuts out, leans out or misfires.	<p>Short circuit in ignition system. Fouled, wet or damaged spark plug. Faulty ignition module, ignition wire or connection. Partial blockage in fuel system. Dirt in fuel lines. Puncture in fuel lines.</p>	<p>Check all wires and connections. Clean and adjust, or replace. See your Authorized Dealer.</p> <p>Clean out carefully and check carburetor. Check and clean. Replace.</p>
Engine lacks power.	<p>Incorrect fuel mixture. Carburetor out of adjustment. Exhaust port or muffler clogged. Air intake filter clogged. Poor compression.</p>	<p>Drain tank, refill with correct mixture. Adjust carburetor. (See Page 11) Clean. Clean or replace. See your Authorized Dealer.</p>
Engine overheats.	<p>Cylinder fins or air system clogged. Incorrect fuel mixture. Carburetor lean Leaking cylinder base or crankcase gaskets. Leaking crankcase seals.</p>	<p>Clean. Drain tank, refill with correct mixture. Adjust. (See Page 11) See your Authorized Dealer. See your Authorized Dealer.</p>

WHEN PERFORMING MAINTENANCE, ENGINE MUST BE TURNED OFF!

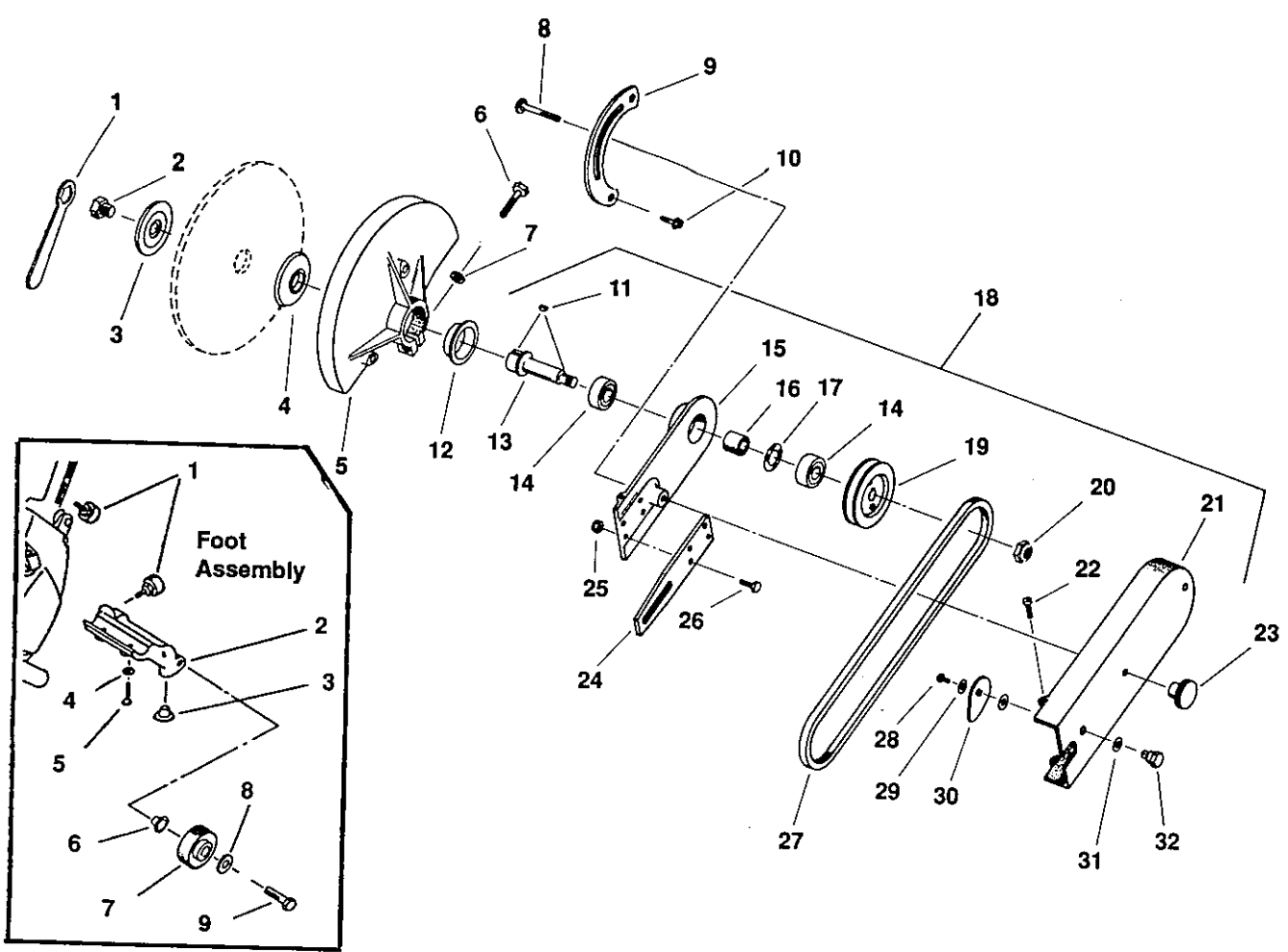

**Blade Guard
Assembly/Foot
Assembly**

Item	Part No.	Qty	Description	Item	Part No.	Qty	Description
1	110551	1	Wrench, Blade Shaft	22	020400	3	Screw
2	020378	1	Capscrew 1/2"-20 UNF X 1"	23	071060	1	Knob
3	071021	1	Outer Flange	24	161570	1	Arm Bar (Model 45)
4	071031	1	Inner Flange		161569	1	Arm Bar (Models 52,65)
5	074036	1	Blade Guard Assy., 12" dia. (includes #6-10,12,23 & Decals)	25	020195	4	Nut, Self-locking, 1/4" dia.
	074038	1	Blade Guard Assy., 14" dia. (includes #6-10,12,23 & Decals)	26	020306	4	Capscrew, 1/4" - 20 X 1" lg.
6	071047	1	Capscrow 5/16"-18 X 1-1/4"	27	161498	1	V-Belt, 3V335 (Model 45)
7	020785	1	Lockwasher, 5/16" dia.		161499	1	V-Belt, 3V355 (Models 52,65)
8	020126	1	Locking Bolt	28	161546	1	Capscrew, Button Hd. 1/4"-20 X 3/4"
9	071050	1	Segment Clamp	29	020794	1	Internal Lockwasher 1/4"
10	020489	2	Screw, 1/4" - 20 X 3/4"	30	161571	1	Adjustment Cam
11	020085	2	Key, Woodruff #404	31	046425	2	Spring Washer
12	074048	1	Bushing	32	161572	1	Adjustment Bolt
13	071070	1	Blade Shaft w/keys		160093	1	Decal - Caution, Guard Top
14	071081	2	Bearing		160504	1	Decal - Caution, Guard Side 12"
15	074052	1	Spindle Arm (Model 45)		160488	2	Decal - Caution, Guard Side 14"
	079067	1	Spindle Arm (Models 52,65)	Foot Assembly			
16	071100	1	Spacer	Item	Part No.	Qty	Description
17	071110	1	Load Spring	1	161543	3	Rubber Bumper
18	161574	1	Spindle Assy. (Model 45) (includes #13-22, 24-26)	2	161505	1	Cast Foot Assy. (items 1-9)
	161573	1	Spindle Assy. (Models 52,65) (includes #13-22, 24-26)	3	161547	2	Plastic Hole Plug
19	079064	1	Pulley, Blade Shaft	4	020784	2	Lockwasher, 1/4"
20	020216	1	Nut, Self Locking 1/2"-20 UNF	5	021422	2	Capscrow, Hex Hd. 1/4"-28 X 2"
21	074051	1	Belt Guard (Model 45)	6	161547	2	Plastic Hole Plug
	074022	1	Belt Guard (Models 52,65)	7	171864	2	Wheel
				8	020764	2	Washer, 3/8" dia.
				9	171870	2	Shoulder Bolt

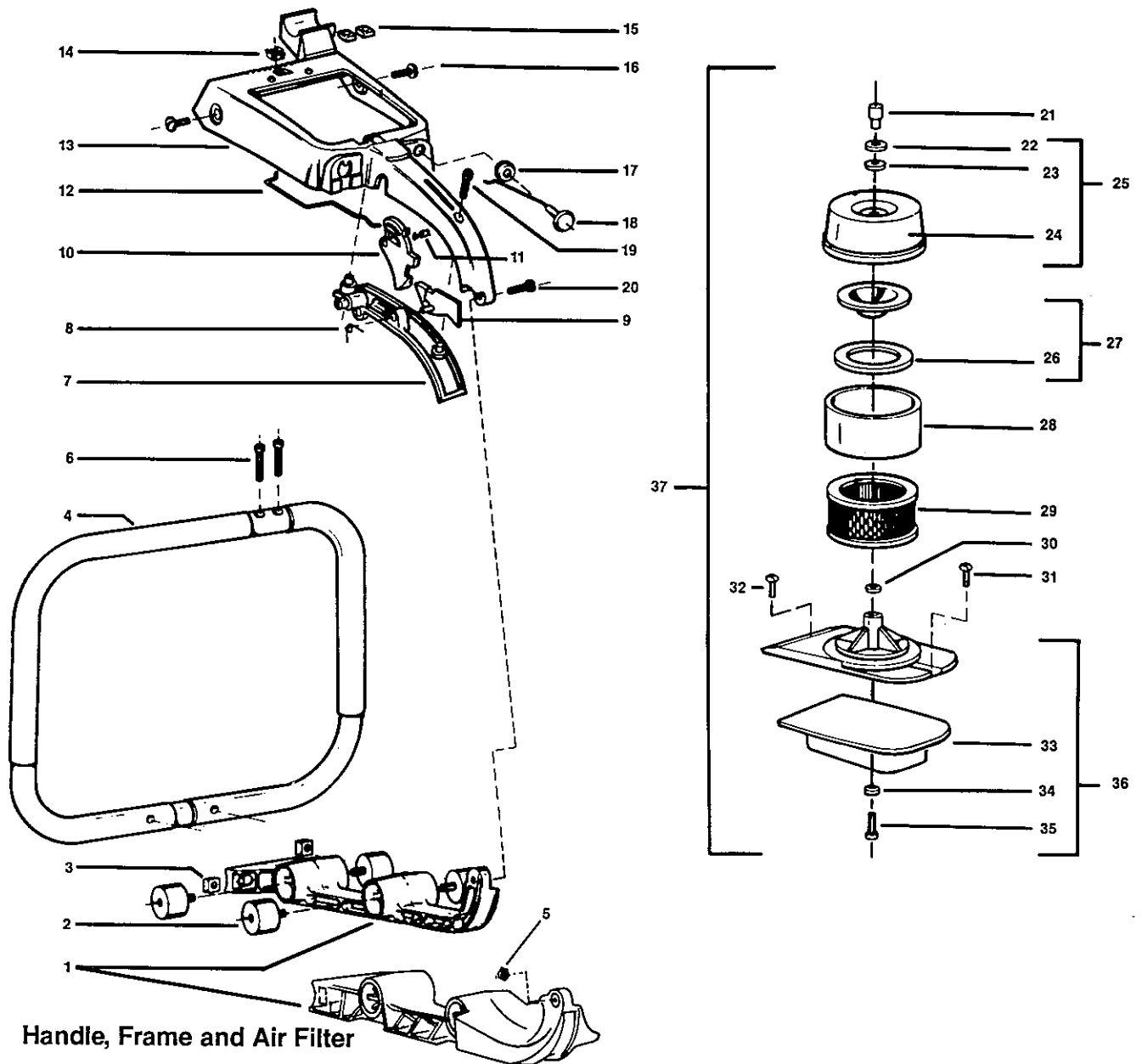

Item	Part No.	Qty	Description	Item	Part No.	Qty	Description
1	14476512	1	Bottom Frame (Model 45) (includes #5)	19	14431705	1	Screw
	14476596	1	Bottom Frame (Models 52, 65)	20	14430887	1	Screw
2	14430197	4	Shock Mount	21	074258	1	Clamping Nut
3	14431655	2	Nut, Handle	22	020745	1	Washer
4	14476193	1	Front Handle (Model 45)	23	074257	1	Gasket (included in #25)
	14476134	1	Front Handle (Models 52, 65)	24	160097	1	Decal (included in #25)
5	14431645	1	Nut (Model 45 only)	25	074255	1	Filter Cover Assy. (includes #22-24)
6	14433184	2	Screw, 1-1/8" lg.	26	074030	1	Gasket, Foam (included in #27)
7	14476502	1	Lower Grip (Model 45)	27	074005	1	Filter Clamp Assy. (includes #26)
	14473935	1	Lower Grip (Models 52, 65)	28	074254	1	Foam Pre-filter
8	14431092	2	Trigger Spring	29	072025	1	Filter Element
9	14430840	1	Safety Trigger	30	074008	1	Gasket, Bolt
10	14430327	1	Throttle Trigger	31	020486	1	Screw, #8 - 32 X 1-3/4"
11	14430399	1	Trigger Pin	32	020484	1	Screw, 1/4"-20 X 1"
12	14430830	1	Throttle Linkage	33	14433321	1	Foam Safety Filter
13	14431174	1	Top Frame	34	020793	1	Lockwasher, 5/16" - 18 X 1"
14	14430203	1	Nut, Frame & Filter Base	35	074253	1	Capscrew, 5/16" - 18 X 1"
15	14431655	2	Nut, Handle	36	074260	1	Filter Assy. Complete (includes #21-35 and #20 on page 20)
16	14432634	2	Screw, Mount	37	074261	1	Filter Assy. Complete (includes #21-35 and #20 on page 20)
17	14429650	1	Grommet				
18	14430202	1	Choke Knob & Wire				

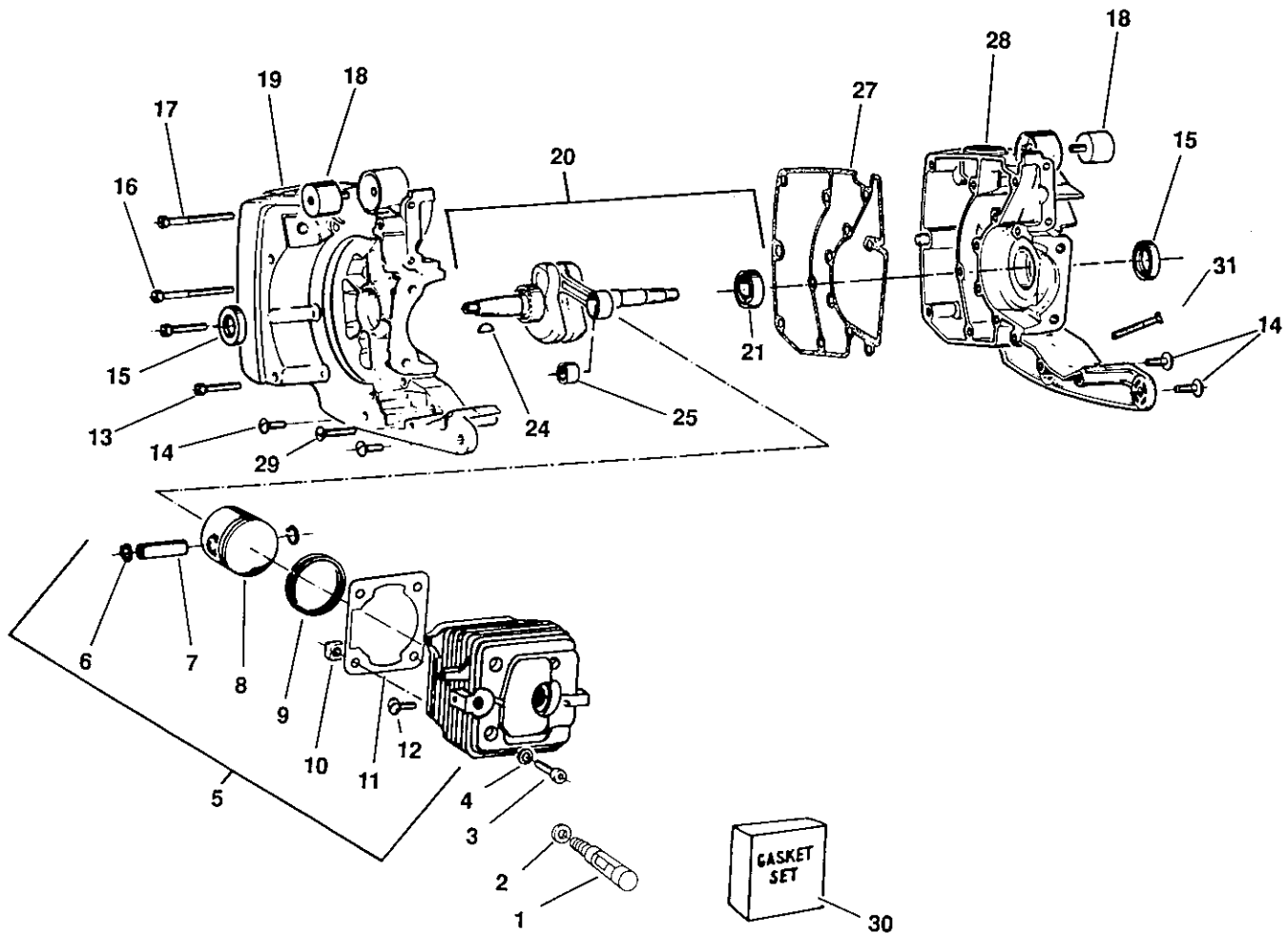

Crankcase and Cylinder 45

Item	Part No.	Qty	Description	Item	Part No.	Qty	Description
1	14475356	1	Decompression Valve	17	14431690	3	Screw, 2-1/4" lg.
2	14432302	1	Washer	18	14430197	2	Shock Absorber
3	14431691	4	Screw, Allen Hd. X 1" lg.	19	144334816	1	Crankcase - Mag Side
4	14431706	4	Washer	20	14476196	1	Crankshaft Assy. (includes #21,24,25)
5	14476661	1	Cylinder Assy. (includes #6-9,11)	21	14433355	2	Bearing
6	14433476	2	Retainer	22	Not Used		
7	14433475	1	Wrist Pin	23	Not Used		
8	14476469	1	Piston	24	14432210	1	Key, Flywheel
9	14476508	1	Ring Set (included in #8)	25	14431408	1	Wrist Pin Bearing
10	14431655	4	Nut (not included in #5)	26	Not Used		
11	14433473	1	Cylinder Base Gasket	27	14430190	1	Gasket
12	14432930	1	Screw	28	144766546	1	Crankcase - Drive Side
13	14431650	9	Screw, 1-1/4" lg.	29	14431642	1	Screw, 1" lg.
14	14432634	6	Screw, Mounting	30	14476509	1	Gasket Set Complete
15	14428746	2	Seal	31	14433533	1	Screw
16	14431658	1	Screw, 2-1/2" lg.				

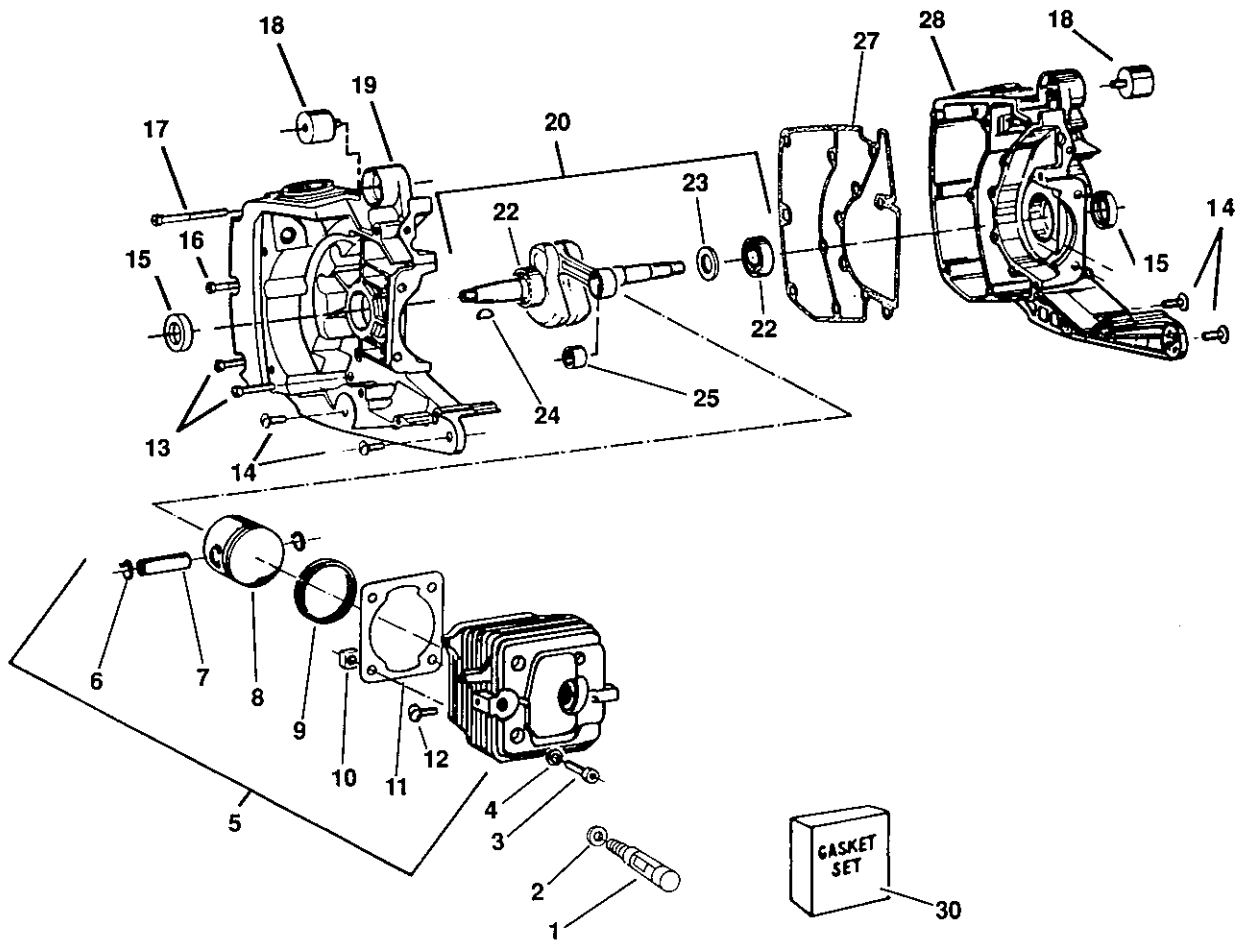

Crankcase and Cylinder 52

Item	Part No.	Qty	Description	Item	Part No.	Qty	Description
1	14475356	1	Decompression Valve	16	14431690	2	Screw, 2-1/4" lg.
2	14432302	1	Washer	17	14431658	1	Screw, 2-1/2" lg.
3	14431691	4	Screw, Allen Hd. X 1" lg.	18	14430197	2	Shock Absorber
4	14431706	4	Washer	19	144332276	1	Crankcase - Mag side
5	14476631	1	Cylinder Assy. (includes #6-9,11)	20	14475422	1	Crankshaft Assy. (includes #22-25)
6	14428781	2	Retainer	21	Not Used		
7	14433221J	1	Wrist Pin	22	14032093	2	Bearing
8	14475398J	1	Piston	23	14430913	2	Thrust Washer
9	14474590	1	Ring Set	24	14432210	1	Key, Flywheel
10	14431655	4	Nut (not included in #5)	25	14433289	1	Wrist Pin Bearing
11	14433226	1	Cylinder Base Gasket	26	Not Used		
12	14432930	1	Screw	27	14430573	1	Gasket
13	14431650	12	Screw, 1-1/4" lg.	28	144762126	1	Crankcase - Drive Side
14	14432634	5	Mounting Screw	29	Not Used		
15	14428746	2	Seal	30	14475492	1	Gasket Set Complete

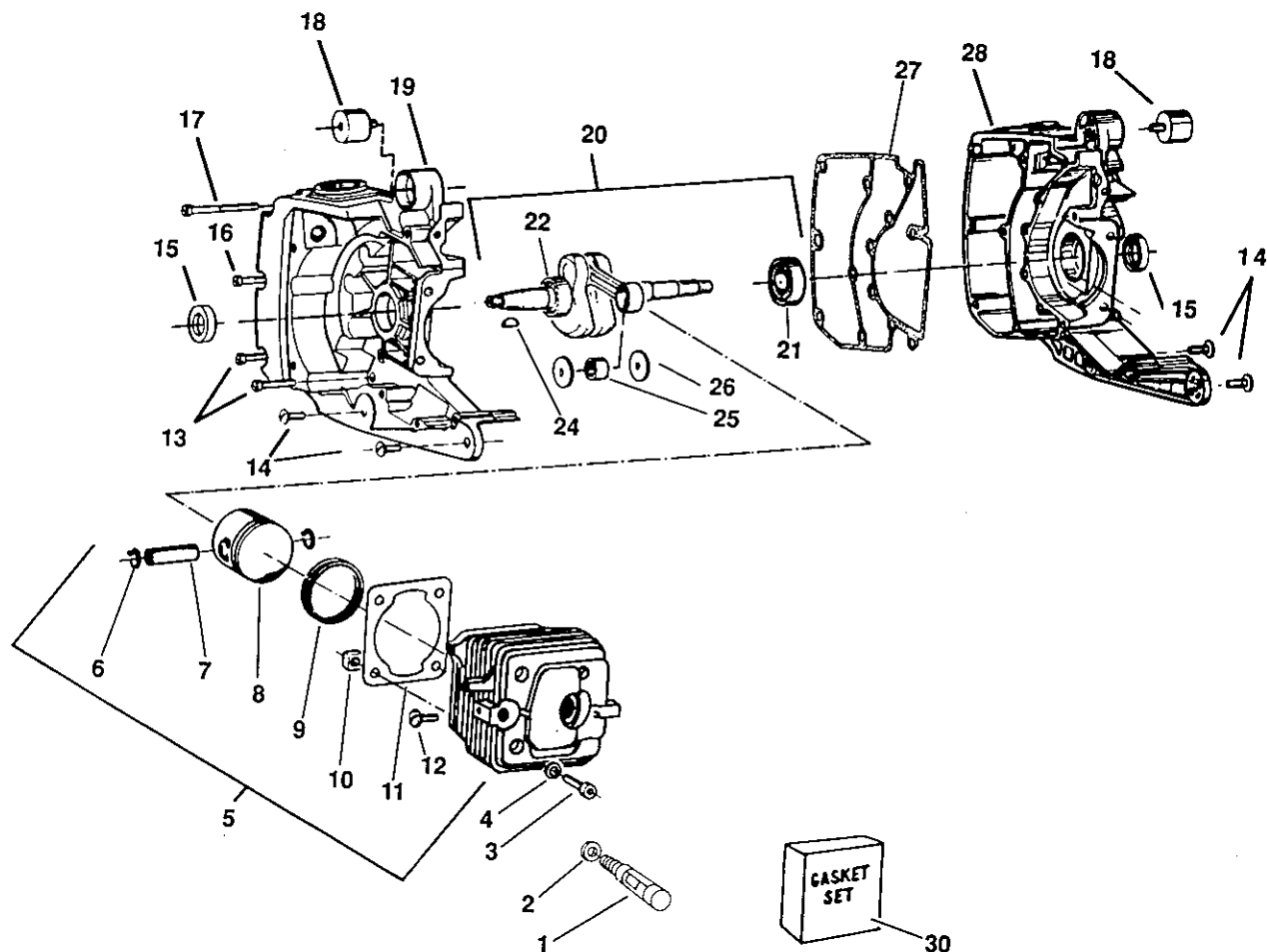

Crankcase and Cylinder 65

Item	Part No.	Qty	Description	Item	Part No.	Qty	Description
1	14475356	1	Decompression Valve	17	14431658	1	Screw, 2-1/2" lg.
2	14432302	1	Washer	18	14430197	2	Shock Absorber
3	14431691	4	Screw, Allen Hd X 1" lg.	19	144332276	1	Crankcase - Mag Side
4	14431706	4	Washer	20	14476542	1	Crankshaft Assy. (includes #21, 22, 24, 25)
5	14476630	1	Cylinder Assy. (includes #6-9,11)	21	14433508	1	Bearing, Drive Side
6	14433756	2	Retainer	22	14433355	1	Bearing
7	14433753	1	Wrist Pin	23	Not Used		
8	14476626	1	Piston	24	14432210	1	Key, Flywheel
9	14476624	1	Ring Set (included in #8)	25	14431408	1	Wrist Pin Bearing
10	14431655	4	Nut (not included in #5)	26	14433689	2	Thrust Washer
11	14433226	1	Cylinder Base Gasket	27	14430573	1	Gasket
12	14432930	1	Screw	28	144766576	1	Crankcase - Drive Side
13	14431650	12	Screw, 1-1/4" lg.	29	Not Used		
14	14432634	5	Screw, Mounting	30	14475492	1	Gasket Set Complete
15	14428746	2	Seal				
16	14431690	2	Screw, 2-1/4" lg.				

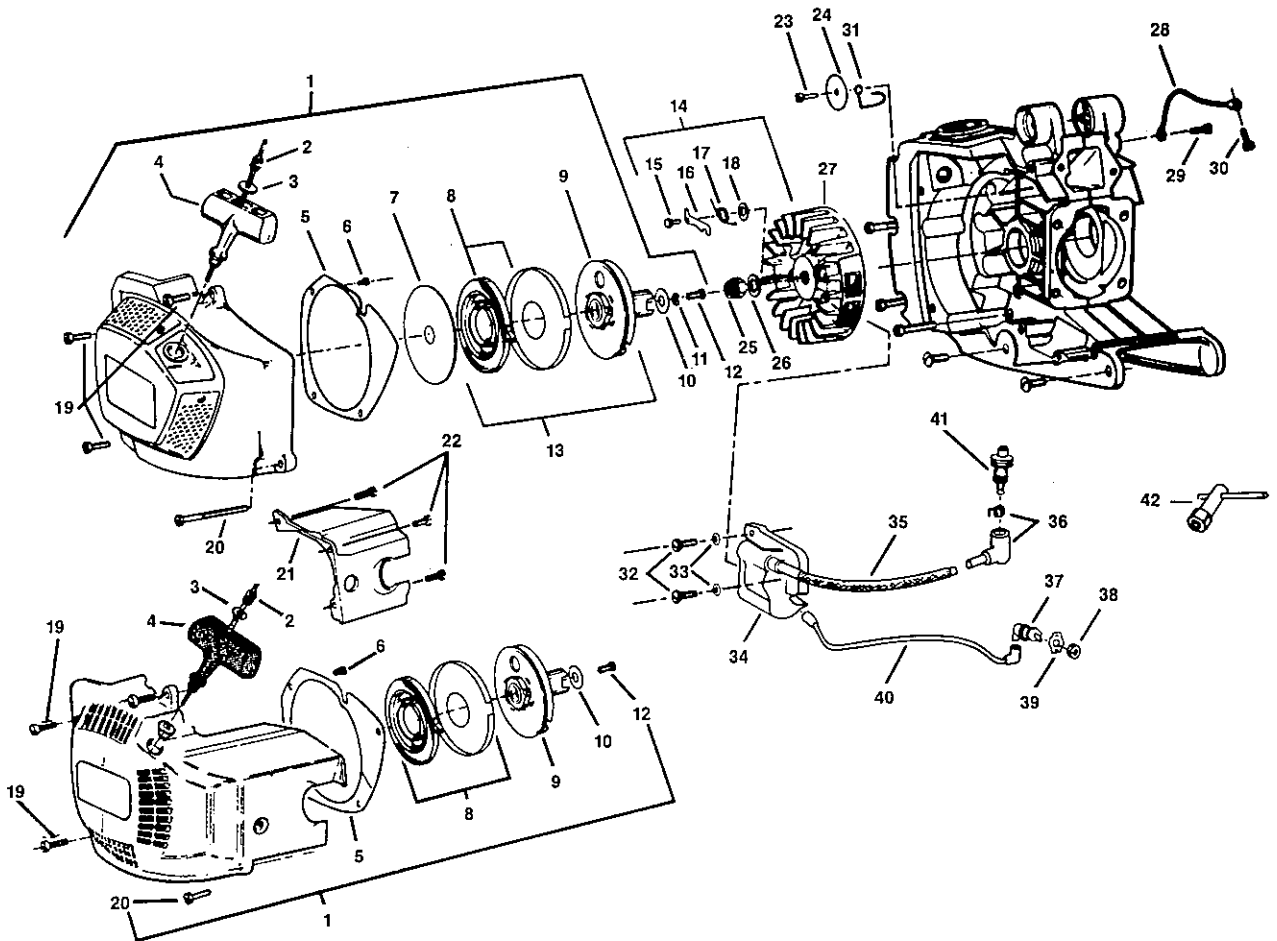

Starter, Flywheel and Ignition (Revised December, 1992)

Item	Part No.	Qty	Description	Item	Part No.	Qty	Description
1	160051	1	Starter Assy. (Model 45) (includes #1-13, 19 & 20)	20	14433158	1	Screw, #10-24 X 7/8" (Model 45)
	160052	1	Starter Assy. (Models 52, 65) (includes #1-13, 19 & 20)		14433159	1	Screw, #10-24 X 1-1/4" (Models 52, 65)
2	074112	1	Rope (includes #3)	21	14432337	1	Shroud (Models 52, 65)
3	14431640	1	Washer (included in #2 and #4)	22	14431649	3	Screw, 5/8" lg.
4	14475297	1	Handle (includes #3)	23	14433611	1	Screw
5	14433584	1	Baffle Plate (Model 45)	24	*4433488	1	Washer (Models 52, 65)
	14430576	1	Baffle Plate (Models 52, 65)	25	14430800	1	Nut
6	14431695	4	Screw, #4 X 1/4" (Models 52, 65)	26	14429851	1	Washer
	14429266	4	Screw #4 X 1/4" (Model 45)	27	14433294	1	Flywheel (Models 45, 52)
7	14430812	1	Washer (fiber) (Model 52, 65 Only)		14476638	1	Flywheel (Model 65)
8	14476600	1	Spring Assy.	28	14430990	1	Ground Wire
9	14476601	1	Pulley Assy. (Model 52, 65)	29	14432930	1	Screw (Models 52, 65)
	14476607	1	Pulley (Model 45)	30	14429266	1	Screw
10	14428105	1	Washer (Model 52, 65)	31	14431022	1	Clip (Model 45)
	14433574	1	Washer (Model 45)	32	14431705	2	Screw, 3/4" lg.
11	14431692	1	Lockwasher (Model 52, 65 Only)	33	14431640	2	Washer
12	14431694	1	Screw, 1/4"20 X 1/2"	34	14476339	1	C.D. Ignition Unit (includes #35, 36)
	14211801	1	Screw (Model 45)	35	14430694	1	Sleeve
13	14476606	1	Spring & Pulley Kit (Model 52, 65 Only)	36	14476096	1	Spark Plug Connector
14	161395	1	Starter Engagement Kit	37	14475623	1	Switch
15	14433776	2	Pawl Pivot (plated)	38	14023575	1	Nut, Switch
16	14433775	2	Pawl (plated)	39	14024858	1	Switch Plate
17	14431416	2	Pawl Spring	40	14433248	1	Switch Wire
18	14430878	2	Washer	41	015080	1	Spark Plug
19	14433157	3	Screw, #10-24 X 3/4" (Model 45)	42	14474945	1	Scrench
	14433158	3	Screw, #10-24 X 7/8" (Models 52, 65)				

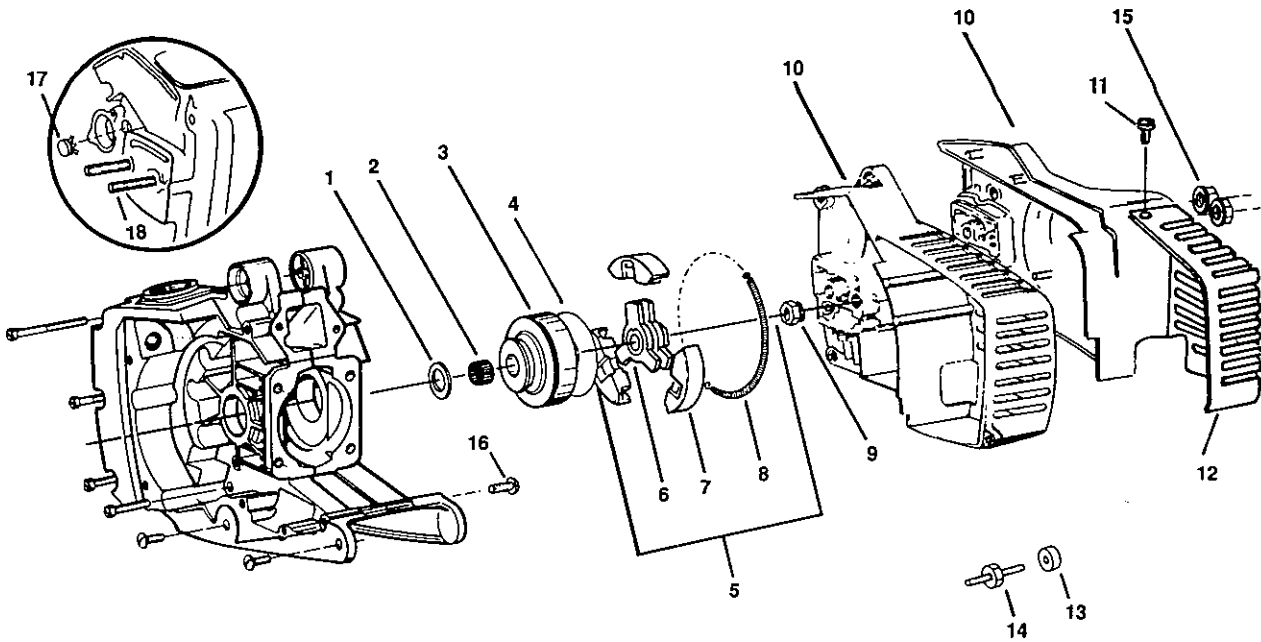

Clutch and Drive

Item	Part No.	Qty	Description	Item	Part No.	Qty	Description
1	14430848	1	Thrust Washer	11	14432930	3	Screw (Model 45 only)
2	14432193	1	Bearing (included in #3)	12	14432896	1	Plastic Guard (Model 45 only)
3	14475360	1	Drum & Bearing Assy.	13	14433042	1	Rubber Bushing (Models 52, 65 only)
4	14430798	1	Clutch Washer	14	14433041	1	Mounting Stud (Models 52, 65 only)
5	14475976	1	Clutch Assy. (includes #6 - 8)	15	14433036	2	Flanged Nut
6	14433133	1	Driver	16	14433533	1	Screw
7	14433102	3	Clutch Shoe	17	14433787	1	Plug, Crankcase
8	14431200	1	Spring	18	14433228	2	Stud
9	14430800	1	Nut				
10	144766536	1	Clutch Cover (Model 45)				
	144333056	1	Clutch Cover (Models 52, 65)				

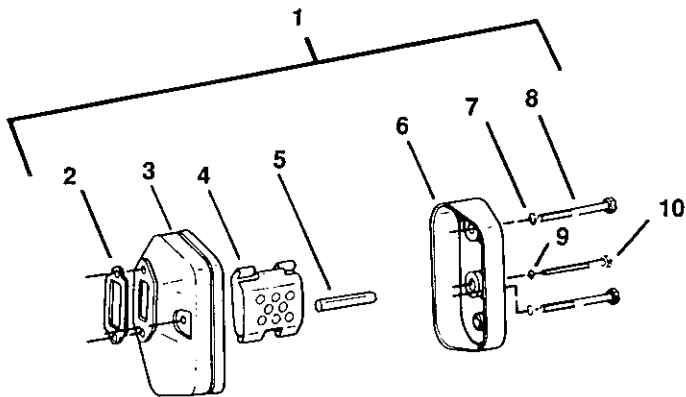

Muffler Assembly

Item	Part No.	Qty	Description
1	14476695	1	Muffler Assy. Complete (includes #2-10)
2	14430684	1	Gasket
3	14476428	1	Muffler Body
4	14433096	2	Exhaust Channel
5	14430835	1	Spacer
6	14476007	1	Muffler Cover
7	14431686	2	Lockwasher
8	14430992	2	Bolt
9	14431683	1	Lockwasher
10	14430993	1	Screw

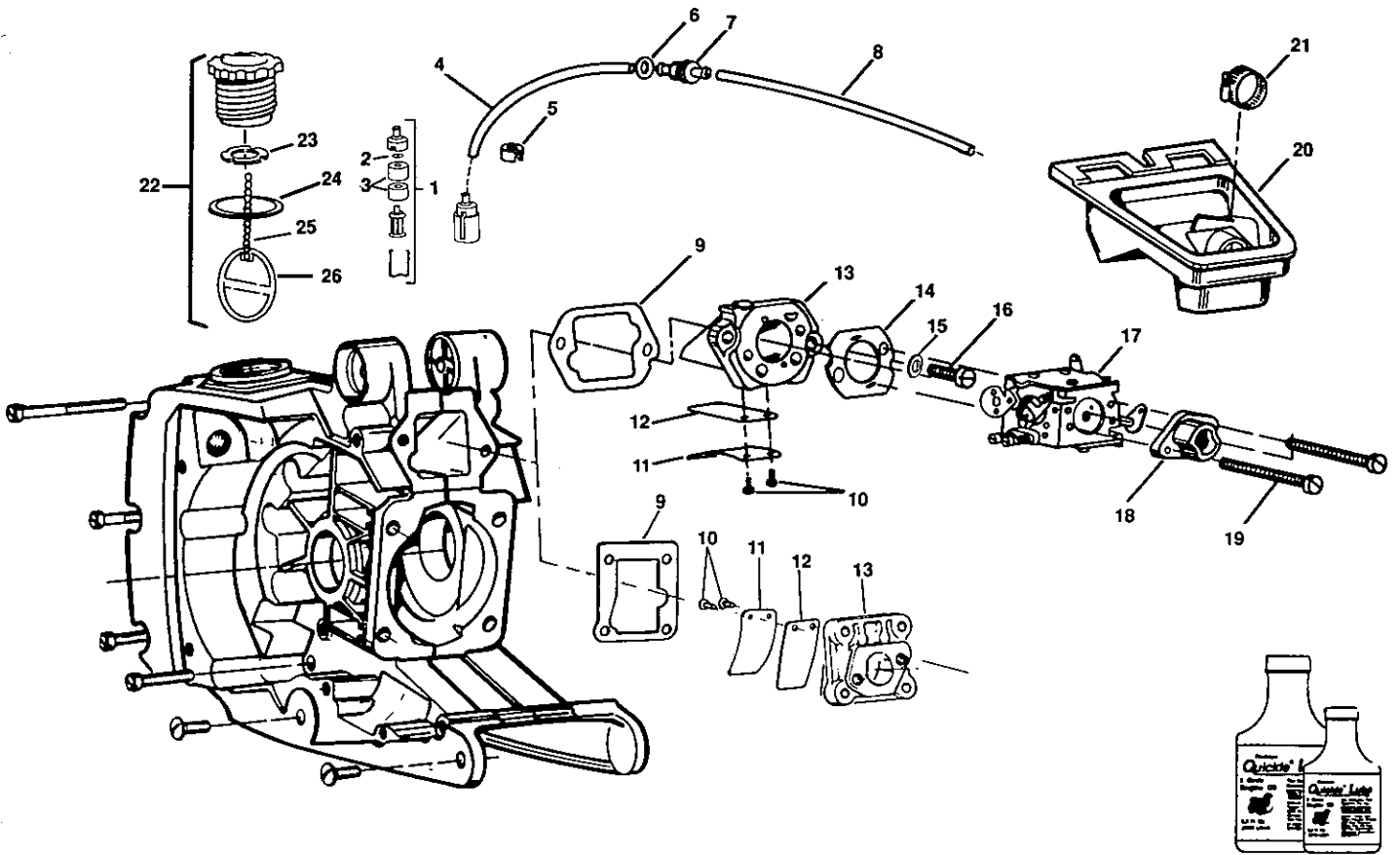

Quickie® Lube 2-Cycle Engine Oil

ITEM DESCRIPTION	ITEM NO.
8 oz. bottle	161039
Case of 48 8 oz.	161040
3.2 oz. bottle	161041
Case of 48 3.2 oz.	161042

Carburetor and Fuel Pickup

Item	Part No.	Qty	Description	Item	Part No.	Qty	Description
1	14476465	1	Pickup Body & Filter Assy. (includes #2 and 3)	14	14432843	1	Carburetor Gasket
2	14476571	1	Screen (Package of 10)*	15	14431688	4	Washer (Model 45)
3	14476570	1	Felt Filter (Package of 10)*	16	14431653	4	Screw (Model 45)
4	14431534	1	Pickup Hose (Model 45)	17	14476559	1	Carburetor Complete
	14431535	1	Pickup Hose (Models 52, 65)	18	14432911	1	Blow-back tube
5	14606801	1	Speed Clip	19	14431657	2	Screw, Carburetor
6	14431271	1	Washer, Connector	20	14432734	1	Intake Boot
7	14431268	1	Fuel Line Connector	21	14432100	1	Clamp
8	14431537	1	Fuel Hose (Model 45)	22	14475167	1	Fuel Cap Assy. (includes #23-26)
	14431536	1	Fuel Hose (Models 52, 65)	23	14427278	1	Locking Plate
9	14430191	1	Gasket, Reed Block (Model 45)	24	14429946	1	O-Ring
	14430859	1	Gasket, Reed Block (Model 52, 65)	25	14431370	1	Bead Chain
10	14432523	2	Screw, Reed (Model 45)	26	14431368	1	Retainer
	14433162	2	Screw, Reed (Models 52, 65)				
11	14432192	1	Backing Plate				
12	14428336	1	Reed (stainless steel)				
13	14475366	1	Reed Valve Assy. (Model 45) (includes #10-12)				
	14476664	1	Reed Valve Assy. (Model 52, 65) (includes #10-12)				

* Available in package of 10 only

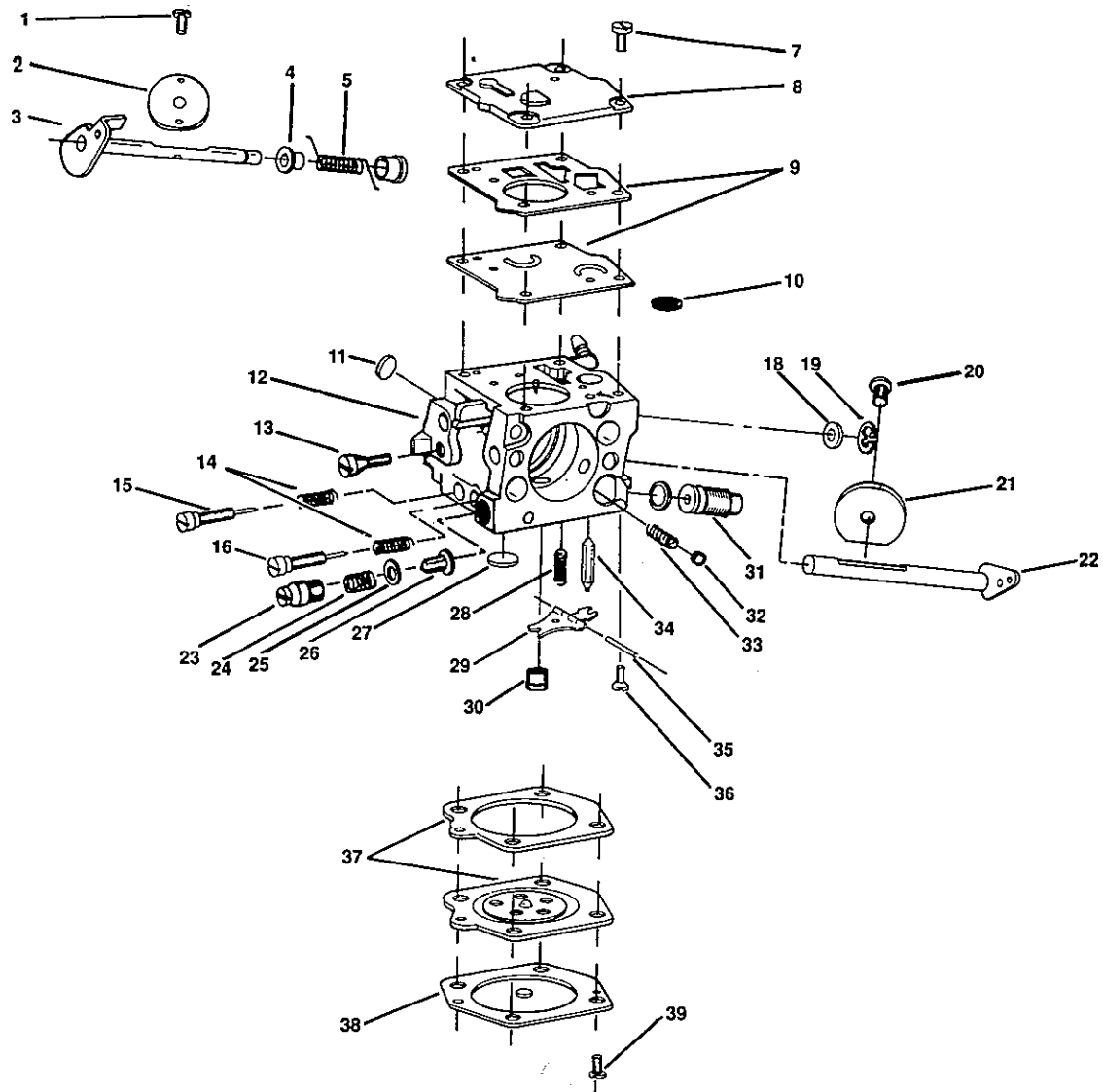

Carburetor Parts & Kits

Item	Part No.	Qty	Description	Item	Part No.	Qty	Description
1		1	Screw	23		1	Plug, Screw
2		1	Throttle Shutter	24		1	Spring, Accelerator Pump
3		1	Throttle Shaft	25		1	Washer
4		2	Bushing	26	▲*	1	Diaphragm, Accelerator Pump
5		1	Spring	27	▲	1	Welsh Plug
6				28	▲	1	Spring, Inlet Lever
7		4	Screw	29	▲	1	Inlet Lever
8		1	Pump Cover	30		1	Discharge Jet
9	▲*	1	Pump Diaphragm & Gasket	31	14433626	1	Governor
10	▲	1	Fuel Screen	32		1	Ball, Choke
11	▲	1	Welsh Plug	33		1	Spring, Choke
12	14476559	1	Carburetor Complete (Walbro)	34		1	Inlet Needle
13		1	Idle Screw	35	▲	1	Inlet Lever Pin
14		2	Spring, low speed adjustment	36	▲	1	Screw
15		1	Low Speed Adjustment Screw	37	▲*	1	Metering Diaphragm & Gasket
16		1	High Speed Adjustment Screw	38		1	Metering Diaphragm Cover
17				39		4	Screw
18		1	Washer	*	14433526	1	Gasket & Diaphragm Set (items marked *)
19		1	E-Clip	▲	14433525	1	Carburetor Repair Kit (items marked ▲)
20		1	Screw				
21		1	Choke Shutter				
22		1	Choke Shaft				