



Ingersoll

[HOME](#)

[TRACTORS](#)

INDEX

42A and 42AC

42A and 42AC Deck shell, covers, gage wheels, chute, roller.....	5
42A and 42AC Deck pulleys, blades, bearings, spindles, gear box, belts	7

52RD

52" Rear Discharge, Deck and Attaching Parts.....	9-11
---	------

52TCSS, 62TCSS and 62TCII

52" Deck shell, covers, gage wheels, chute, roller	13
52" Deck pulleys, blades, bearings, spindles, gear box, belts.....	15
62" Deck shell, covers, gage wheels, chute, roller	17
62" Deck pulleys, blades, bearings, spindles, gear box, belts.....	19

Gear Box, Curtis and Superior (Mower)	21
Decals	23

INDEX

There is an index at the front of this catalog. The front index is an alphabetical index of the major groups or assemblies.

ILLUSTRATION

Each illustration in this catalog shows a group of parts or components. These parts and components are aligned approximately as the parts and components on your machine. Each part and component in an illustration has a reference number. These reference numbers are in a list on the page opposite of the illustration. Next to the reference number is the part number, description and required quantity of the part shown in the illustration.

UAR - "Use as required" indicates that the part quantity is variable.

NSS - "Not sold separately" indicates that the part is only available as component of an assembly or the part must be purchased locally. If the part is an assembly component, the description will be indented under the assembly description in the parts list.

O/L - "Obtain locally"

- "Footnotes" are added to a part number when more information is needed for identification. They only relate to the part numbers indicated. All orders must include the following information:

1. Correct part number.

PARTS ORDERS

2. Complete description of part or component.
3. Total quantity of each part or component.
4. Product model number.
5. All necessary product identification numbers.
6. Method for sending the parts.
7. Complete and correct address.

CATALOG REVISIONS

As the product changes, new pages will be available for your catalog. A notice will be issued.

IMPORTANT: Put all revisions into the catalog as soon as possible.

RIGHT HAND AND LEFT HAND IDENTIFICATION

The words right hand (RH) and left hand (LH) as used in this catalog indicate the direction while you are in the operator's seat in the normal operating position.

INDENTED DESCRIPTIONS

An assembly can have many components. The components of an assembly are indicated by an indented description. The quantity for an indented part is the total needed for that complete assembly. See the example.

REF.	PART NO.	DESCRIPTION	REQ'D
	C 55159	CYLINDER ASSY - rear steering	1
28	C 56208	SOCKET ASSY - rear cylinder	1
29	C 55956	PLUG - adjusting, socket assy	1
30	C 55957	SEAT- socket, ball.....	2
31	C 56210	SPRING-socket	1
32	C 56209	SEAT - socket spring	1
33	G 45175	CLAMP ASSY - socket assy	1
	16- 836	BOLT-1/2"x2-1/4" N.F. hex.....	1
34	132- 104	PIN-cotter, 3/16"x3"	1
35	C 55889	STUD - ball, socket & cylinder	2
36	13- 410	BOLT-1/4"x5/8"N.C.,hex	4
37	92- 4	LOCK WASHER - 1/4"SAE	4

INDEX

PAINT AND OIL

PAINT

REF.	PART NO.	DESCRIPTION	REQ'D
1	C 28849	BLACK - semi - gloss, 12 oz spray (2 per carton)	1
2	C 28850	BLACK - semi - gloss, quart (2 per carton)	1
3	C 28850	BLACK - semi - gloss, heat resistant, 12 oz spray (2 per carton)	1
4	C 28484	POWER RED - gloss, 12 oz spray (2 per carton)	1
5	C 28485	POWER RED - gloss, quart (2 per carton)	1
6	C 30870	SILVER - gloss, 12 oz. spray (2 per carton).....	1
7	C 31643	POWER RED - gloss, 1 oz touch up, (1 doz. per carton)	1

OIL

1	C 32776	OIL - SAE 30, SF, quart (12 per case)	1
2	C 32777	OIL - SAE 5W20, SF, quart (12 per case)	1
3	C 32778	OIL - SAE 20W40, SF, quart (12 per case)	1

INDEX

**MODEL 42A AND 42AC MOWER DECK
MOWER DECK AND ATTACHING PARTS (42")**

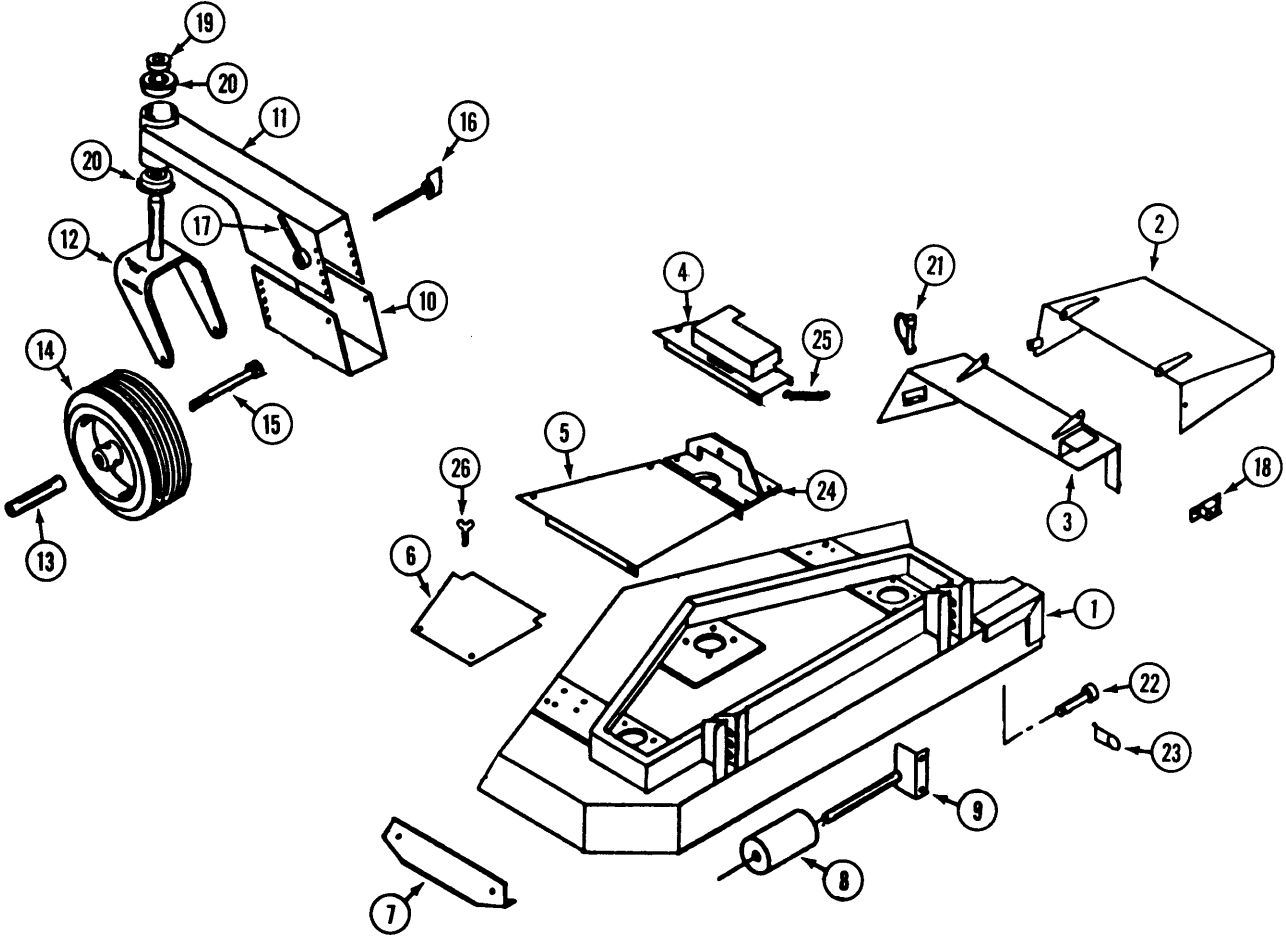

INDEX

**MODEL 42A AND 42AC MOWER DECK
MOWER DECK AND ATTACHING PARTS (42")**

REF.	PART NO.	DESCRIPTION	REQ'D
1	C41249	DECK - 42"	1
2	C44612	CHUTE - foot guard	1
3	C39209	MOUNT - foot guard.....	1
4	C41255	COVER - pulley.....	1
5	C41259	COVER - center	1
6	C38107	COVER - L.H.....	1
7	C37909	SHOE - skid L.H.....	1
8	C37910	ROLLER - anti-scalp	1
9	C37911	SHAFT - roller	1
10	C37912	BRACKET - gauge wheel mount	2
11	C37913	MOUNT - gauge wheel	2
12	C37914	FORK - (42AC) use on G2000.....	2
12	C38030	FORK - (42A)	2
13	C37915	AXLE - wheel (42AC) use on G2000	2
13	C38031	AXLE - wheel (42A).....	2
14	C37916	WHEEL - gauge (42AC) use on G2000	2
14	C38032	WHEEL - gauge (42A)	2
	C37917	TIRE - 11 x 4.00-5	1
	C37918	RIM - 5"	1
	C44499	BEARING - wheel (42AC) use on G2000.....	2
	C38033	BEARING - wheel (42A)	2
15	113-54	BOLT - 1/4" - 20 x 4-1/2" (42A)	2
15	113-2419	BOLT - 1/2" - 13 x 6-1/2" (42AC) use on G2000.....	2
16	C37920	BOLT - wing	4
17	C37921	NUT - gauge wheel handle	4
18	C37505	BREAKER - circuit 10 amp	1
19	C37860	COLLAR - set 1"	2
20	C37824	BEARING - 1"	4
21	C37922	PIN - "fas-tatch"	1
22	141-56	PIN - deck.....	2
23	C38096	PIN - cotter, hair	2
24	C37925	MOUNT - deck	1
25	C37926	SPRING.....	1
26	NSS	SCREW - thumb 1/4" - 20 x 1/2" (use 113-3 and 192-19)	4

MODEL 42A AND 42AC MOWER DECK

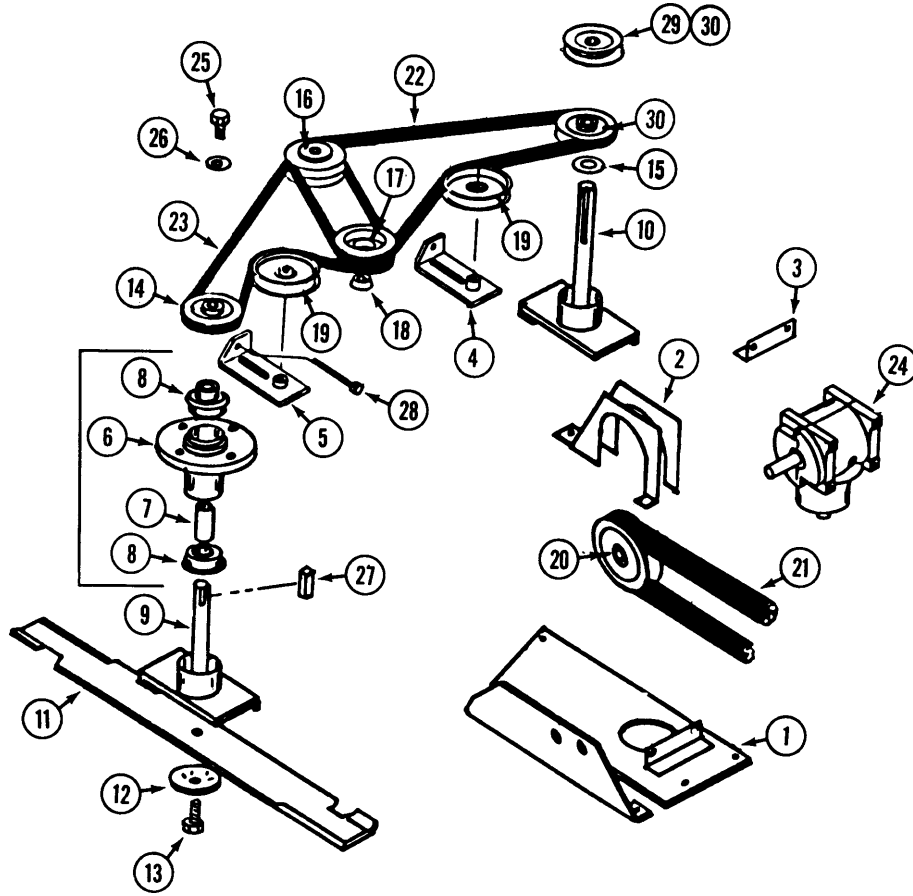

INDEX

MODEL 42A AND 42AC MOWER DECK

REF.	PART NO.	DESCRIPTION	REQ'D
1	C41269	MOUNT - gear box.....	1
2	C37875	GUARD - belt, for model 42A (All except G2000CII)	1
2	C37876	GUARD - belt for model 42AC (G2000CII)	1
3	C37877	ANGLE - gear box mount.....	1
4	C37878	TIGHTENER - belt	1
5	C37879	TIGHTENER - belt	1
6	C37880	HOUSING - spindle.....	3
7	C37881	SPACER - spindle.....	3
8	C42786	BEARING - spindle	6
9	C37883	SHAFT - spindle.....	2
10	C37884	SHAFT - spindle.....	1
11	C37885	BLADE - for model 42AC (G2000CII)	3
11	C38036	BLADE - for model 42A.....	3
12	C37886	WASHER - blade	3
13	C37557	BOLT - 3/8" - 24 x 1-1/4"	3
14	C37887	PULLEY - spindle.....	2
15	C37888	WASHER - spacer	9
16	C37889	PULLEY - spindle, double.....	1
17	C37890	PULLEY - gear box output	1
18	C41658	HUB - pulley.....	1
19	C37891	PULLEY - idler	2
20	C37892	PULLEY - gear box input, for model 42A.....	1
20	C37893	PULLEY - gearbox input, for model 42AC (G2000CII)	1
21	C44241	BELT - drive (Use on all units with Vanguard Engines).....	1
21	C37894	BELT - drive, for (All others except G2000CII)	1
21	C37895	BELT - drive, for model 42AC (G2000CII)	1
22	C37896	BELT - deck	1
23	C37897	BELT - deck	1
24	C37898	GEAR BOX - see page 83 for repairs (Curtis model)	1
25	C39386	BOLT - 5/16" - 24 x 3/4"	3
26	C37900	WASHER - 5/16", 10 gage.....	3
27	C29581	KEY - 3/16" x 3/16" x 1".....	6
28	C37901	BOLT - 1/4" - 20 x 4"	2
29	C38037	PULLEY - spindle for model 42A (All except G2000CII).....	1
30	C37887	PULLEY - spindle, for model 42AC (G2000CII).....	1
31	C37902	HOUSING ASSEMBLY - spindle (includes ref. 6, 7, 8)	1

MOWER DECK AND ATTACHING PARTS (52" Rear Discharge) (also see page 69 for reference #'s 36 to 70)

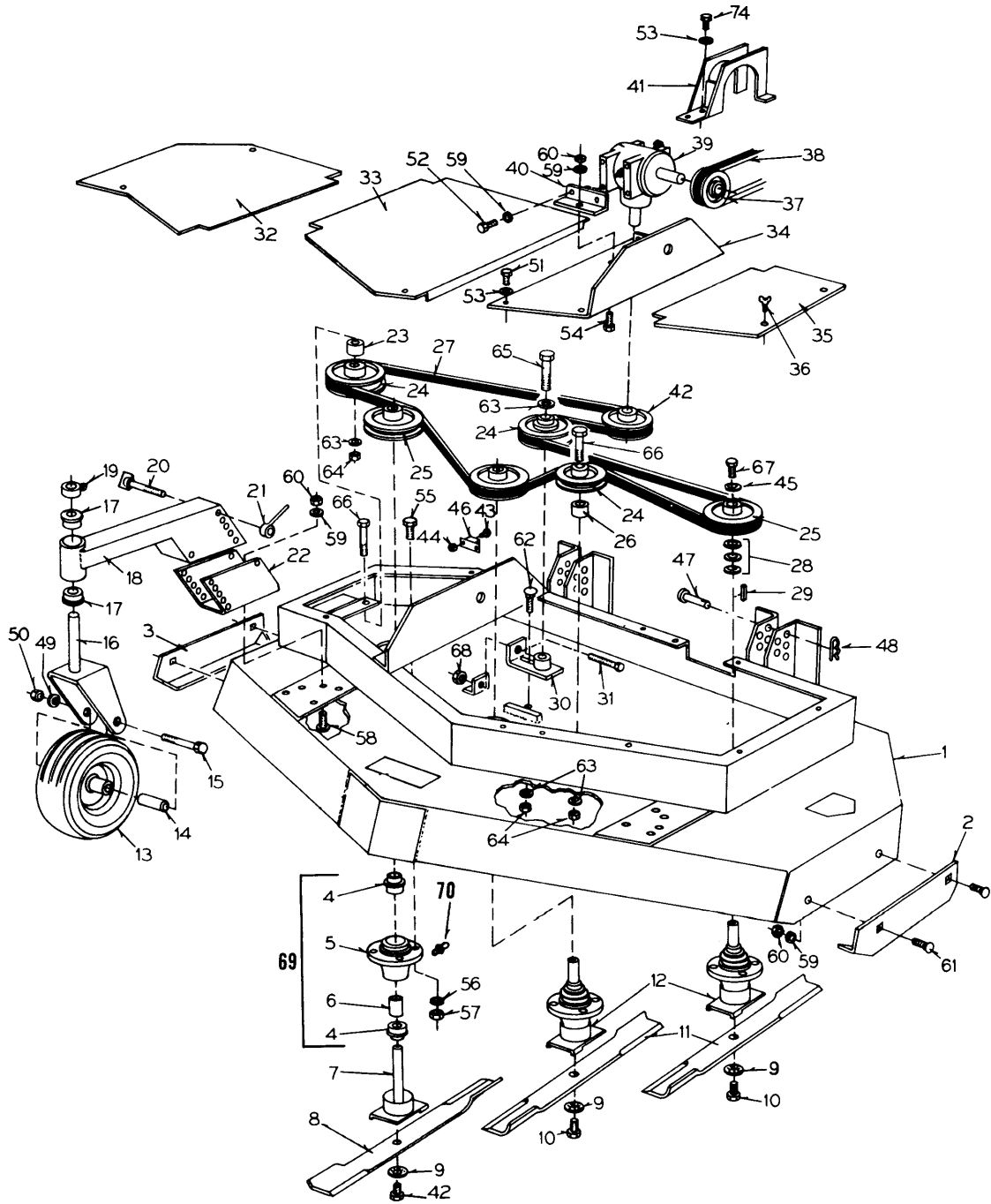

INDEX

MOWER DECK AND ATTACHING PARTS
(52" Rear Discharge)
(also see page 69)

REF.	PART NO.	DESCRIPTION	REQ'D
1	C44087	DECK - rear discharge 52".....	1
2	C37942	SHOE - skid L.H.....	1
3	C38073	SHOE - skid R.H.....	1
4	C37882	BEARING - spindle 7/8.....	6
5	C37880	HOUSING - spindle.....	3
6	C37881	SPACER - spindle.....	3
7	C38074	SHAFT - spindle L.H. rotation.....	1
8	C38075	BLADE - L.H. rotation.....	1
9	C37886	WASHER - blade.....	3
10	C37557	BOLT - 3/8" - 24 x 1-1/4".....	2
11	C37930	BLADE - R.H. rotation.....	2
12	C37883	SHAFT - spindle.....	2
13	C37916	WHEEL-gauge.....	2
	C37917	TIRE - 11 x 4.00-5.....	1
	C37918	RIM-5".....	1
	C44499	BEARING - wheel.....	2
14	C37915	AXLE - gauge wheel.....	2
15	113-2419	BOLT - 1/2" - 13 x 6-1/2".....	2
16	C37914	FORK - gauge wheel.....	2
17	C37824	BEARING - 1".....	4
18	C37913	MOUNT - gauge wheel.....	2
19	C37860	COLLAR - set 1".....	2
20	C37920	BOLT - wing 3/8" - 16 x 4-1/2".....	4
21	C37921	NUT - gauge wheel handle 3/8" - 16.....	4
22	C37912	BRACKET - gauge wheel mount.....	2
23	C38076	SPACER - idler pulley.....	1
24	C38077	PULLEY - idler 5".....	3
25	C38078	PULLEY - spindle 4-1/2.....	3
26	C37937	SPACER - idler pulley.....	1
27	C38079	BELT - deck.....	1
28	C37888	WASHER - spacer.....	9
29	C29581	KEY - 3/16" x 3/16" x 1".....	5
30	C38080	TIGHTENER - belt.....	1
31	C37901	BOLT - 1/4" - 20 x 4".....	1
32	C42230	COVER - R.H.....	1
33	C39203	COVER - center.....	1
34	C39205	MOUNT - gear box.....	1
35	C39200	COVER - L.H.....	1

REF'S 36 TO 70

MOWER DECK AND ATTACHING PARTS (52" Rear Discharge)

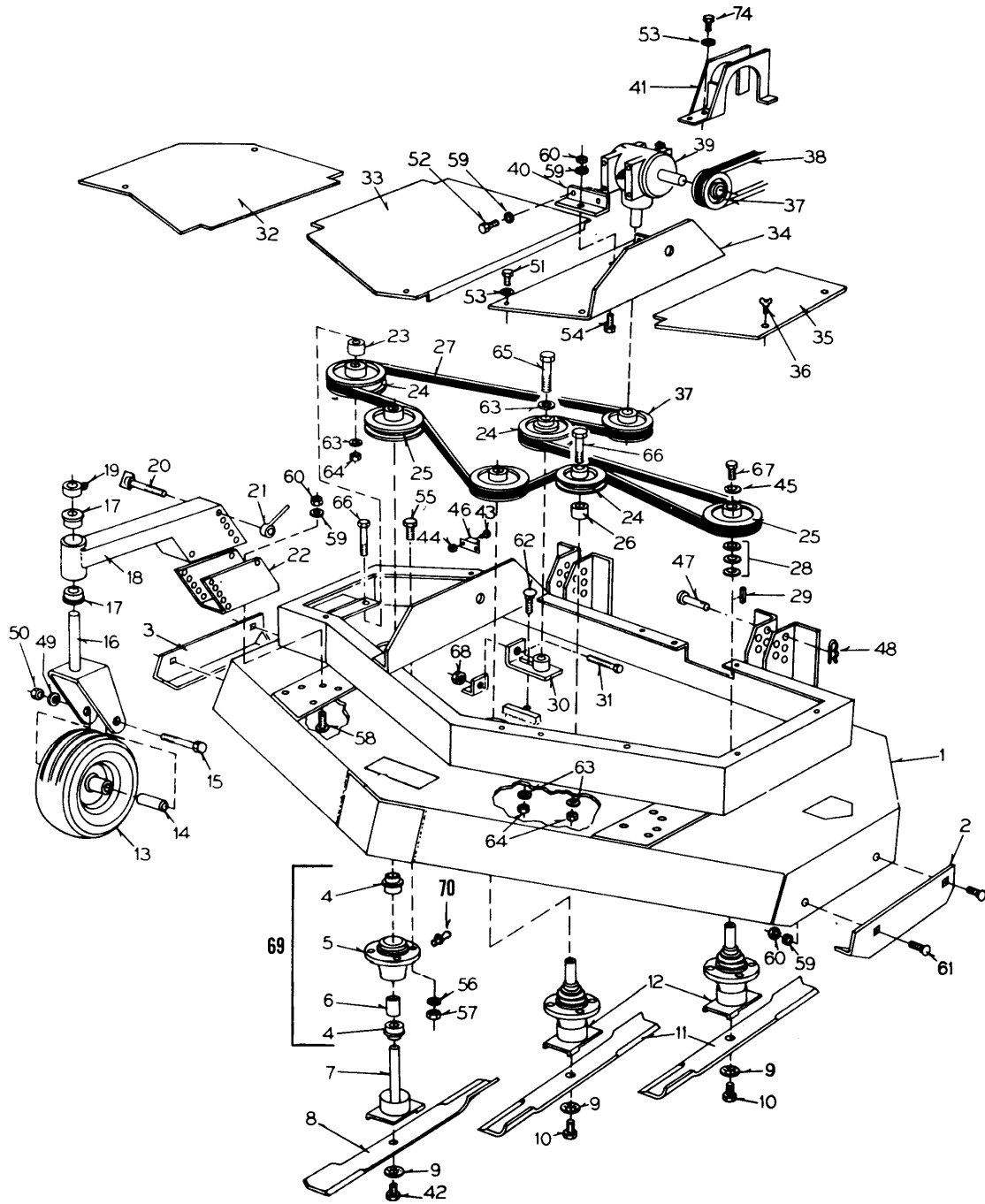

MOWER DECK AND ATTACHING PARTS (52" Rear Discharge)

1 - 35

REF.	PART NO.	DESCRIPTION	REQ'D
36	NSS	SCREW - thumb 1/4" - 20 x 1/2" (use 113-3 and 192-19)	6
37	C37892	PULLEY - gear box input	1
38	C37894	BELT - drive (1890, 1890K, 1800SS, 1800KSS)	1
38	C44241	BELT - drive (1890V)	1
39	C37898	GEAR BOX - angle drive (see page 83 for service) (Curtis model)	1
39	C42775	GEAR BOX - angle drive (see page 83 for service) (Superior model)	1
40	C37877	ANGLE - gear box mount	1
41	C37875	GUARD - belt	1
42	C38083	BOLT - 3/8" - 24 x 1-1/4" L.H	1
43	C37597	SCREW - #10 - 32 x 1/2"	2
44	193-1000	NUT - lock #10 - 32	2
45	C37900	WASHER - spindle	3
46	C37505	BREAKER - circuit 10 amp	1
47	C10821	PIN - clevis 1/2" x 1-1/2"	2
48	C38096	PIN - cotter, hair	2
49	C37590	LOCKWASHER - 1/2"	2
50	C37593	NUT - 1/2" - 13	2
51	C38084	BOLT - 1/4" - 20 x 3/4"	5
52	C38085	BOLT - 5/16" - 18 x 1"	4
53	C37757	LOCKWASHER - 1/4"	7
54	C38086	BOLT - 5/16" - 18 x 3/4"	1
55	C38087	BOLT - 7/16" - 14 x 1-1/4"	1
56	C38088	LOCKWASHER - 7/16"	12
57	C38089	NUT - 7/16"-14	12
58	C38090	BOLT - carriage 5/16" - 18 x 1"	6
59	C37748	LOCKWASHER - 5/16"	10
60	C37560	NUT - 5/16"	10
61	C38091	BOLT - carriage 5/16" - 18 x 3/4"	4
62	C38092	BOLT - carriage 3/8" - 16 x 1"	1
63	C37591	LOCKWASHER - 3/8"	4
64	C37592	NUT - 3/8" -16	3
65	C38093	BOLT - 3/8" - 16 x 1-1/4"	1
66	C38094	BOLT - 3/8" - 16 x 2-1/2	2
67	C37899	BOLT - 5/16" - 24 x 3/4"	3
68	C37734	NUT - lock 1/4" - 20	3
69	C37902	HOUSING ASSEMBLY - spindle (includes ref. 4, 5 and 6)	3
70	219-20	FITTING - grease 1/4" - 28	3

INDEX

MOWER DECK AND ATTACHING PARTS (52")

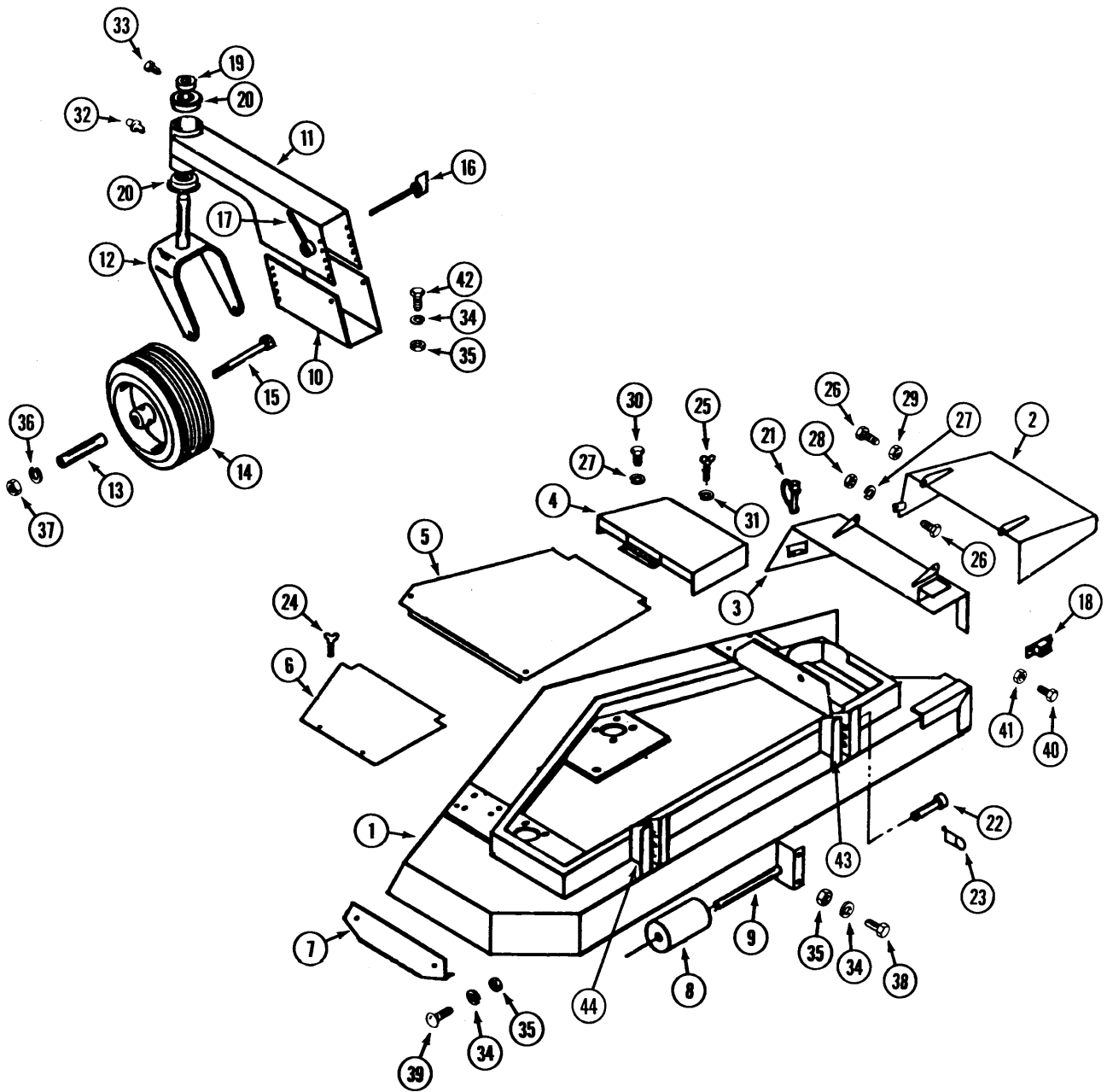

52" MOWER DECK AND ATTACHING PARTS

REF.	PART NO.	DESCRIPTION	REQ'D
1	C44086	DECK - 52"	1
2	C39208	CHUTE - foot guard	1
3	C39209	MOUNT - foot guard.....	1
4	C39204	COVER - pulley.....	1
5	C39203	COVER - center	1
6	C39200	COVER - L.H.....	1
7	C37942	SHOE - skid	1
8	C37910	ROLLER - anti-scalp	1
9	C37911	SHAFT - roller	1
10	C37912	BRACKET - gauge wheel mount	2
11	C37913	MOUNT - gauge wheel	2
12	C37914	FORK	2
13	C37915	AXLE - wheel	2
14	C37916	WHEEL - gauge	2
	C37917	TIRE - 11 x 4.00 - 5	1
	C37918	RIM - 5"	1
	C44499	BEARING - wheel.....	2
15	113-2419	BOLT - 1/2" - 13 x 6-1/2"	2
16	C37920	BOLT - wing	4
17	C37921	NUT - gauge wheel handle	4
18	C37505	BREAKER - circuit, 10 amp	1
19	C37860	COLLAR - set.....	2
20	C37824	BEARING - 1".....	4
21	C37922	PIN - "fas-tatch".....	1
22	C10821	PIN - deck.....	1
23	C29029	PIN - cotter, hair	2
24	NSS	SCREW - thumb 1/4" - 20 x 1/2" (use 113-3 and 192-19)	4
25	NSS	SCREW - wing 1/4" -20 x 1" (use 113-3)	1
26	113-3	BOLT - 1/4" - 20 x 3/4"	4
27	192-19	LOCKWASHER - 1/4"	2
28	129-101	NUT - 1/4" -20	2
29	131-71	NUT - 1/4" - 20 lock.....	2
30	113-1	BOLT - 1/4" - 20 x 1"	2
31	195-102	WASHER - 1/4"	1
32	C37993	FITTING - grease	2
33	C37756	SCREW - set 5/16" - 18 x 1/2" square head	2
34	192-20	LOCKWASHER - 5/16"	6
35	129-102	NUT - 5/16" - 18	6
36	192-23	LOCKWASHER - 1/2"	2
37	129-105	NUT- 1/2" -13	2
38	113-102	BOLT - 5/16" - 18 x 3/4"	2
39	111-202	BOLT - 5/16" - 18 x 3/4" carriage	2
40	182-528	SCREW - #10 - 32 x 1/2"	2
41	C37598	NUT - #10-32	2
42	111-203	BOLT - 5/16" - 18 x 1" carriage	6

52" MOWER DRIVE

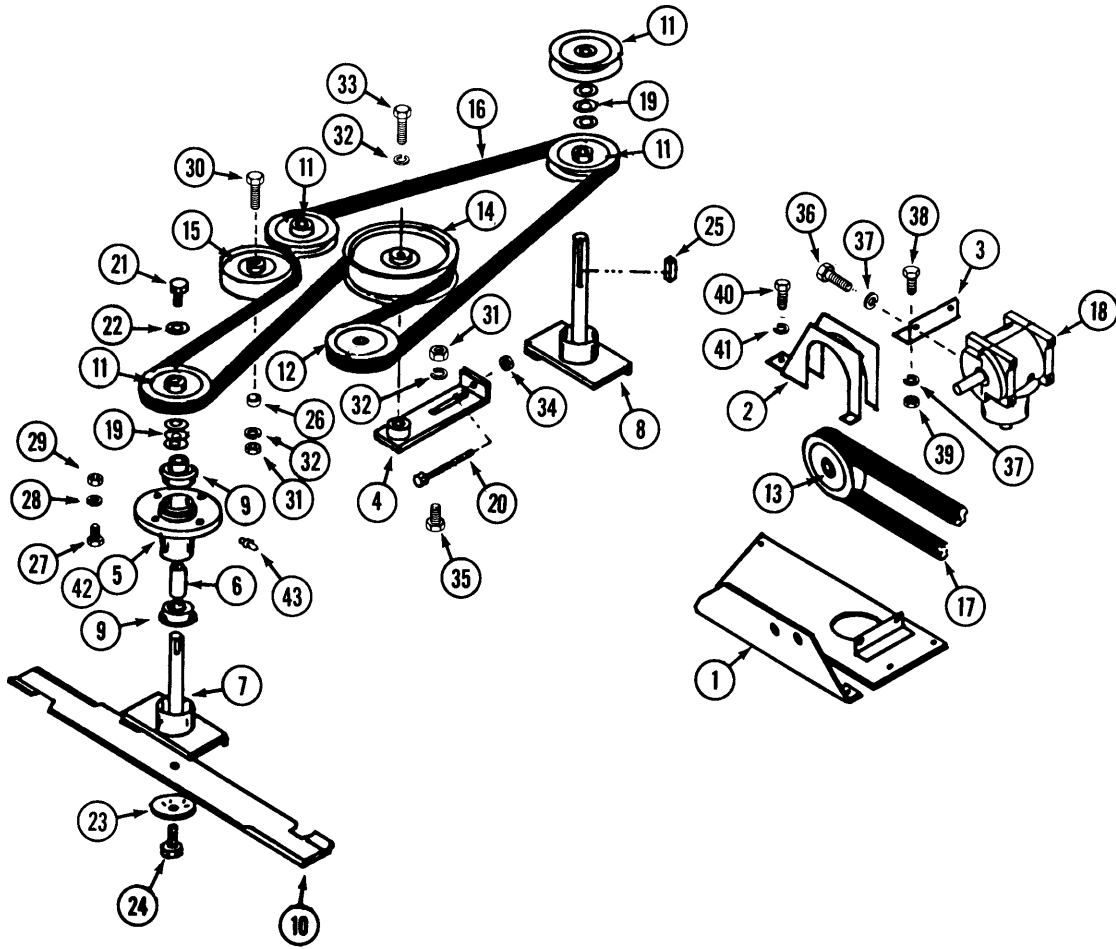

INDEX

52" MOWER DRIVE

REF.	PART NO.	DESCRIPTION	REQ'D
1	C39205	MOUNT - gear box.....	1
2	C37876	GUARD - belt (for G2000CII).....	1
2	C37875	GUARD - belt (All except G2000CII).....	1
3	C37877	ANGLE - gear box mount.....	1
4	C37929	TIGHTENER - belt	1
5	C37880	HOUSING - spindle.....	3
6	C37881	SPACER - spindle.....	3
7	C37883 *	SHAFT - spindle, short.....	2
7	C44128 **	SHAFT - spindle, short.....	1
8	C37884 *	SHAFT - spindle, long.....	1
8	C44130 **	SHAFT - spindle, long.....	1
9	C42786 *	BEARING - spindle	3
10	C37930	BLADE - mower	3
10	C44136 **	BLADE - mower	1
11	C37931	PULLEY - spindle.....	4
12	C37932	PULLEY - gear box output.....	1
13	C37892	PULLEY - gear box input (All except G2000CII).....	1
13	C37893	PULLEY, double - gear box input (G2000CII).....	1
14	C37933	PULLEY - idler, large	1
15	C37934	PULLEY - idler, small.....	1
16	C37935	BELT - deck	1
17	C37894	BELT - drive (G1800SS, G1800KSS, G1890, G1890K).....	1
17	C37895	BELT - drive (G2000CII)	2
17	C44241	BELT - drive (1890V)	1
18	C37898	GEAR BOX - angle drive (see page 83 for repairs) (Curtis model).....	1
18	C42775	GEAR BOX - angle drive (see page 83 for repairs) (Superior model).....	1
19	C37888	SPACER - washer.....	12
20	C37901	BOLT - 1/4" - 20 x 4".....	1
21	C39386	BOLT - 5/16" - 24 x 3/4" lock.....	3
22	C37900	WASHER - 5/16" - 10 gage.....	3
23	C37886 *	WASHER - blade	3
24	C37557 *	BOLT - 3/8" - 24 x 1-1/4".....	3
24	113-268 **	BOLT - 3/8" - 16 x 1" (also required 131-1216 locknut).....	6
25	C29581	KEY - 3/16" x 1".....	6
26	C37937	SPACER - idler pulley.....	1
27	113-312	BOLT - 7/16" - 14 x 1-1/4".....	12
28	192-22	LOCKWASHER - 7/16"	12
29	129-104	NUT - 7/16" - 14	12
30	113-257	BOLT - 3/8" - 16 x 2-1/2".....	1
31	129-103	NUT - 3/8".....	1
32	192-21	LOCKWASHER - 3/8"	1
33	113-208	BOLT - 3/8" - 16 x 1-1/4".....	1
34	131-71	NUT - 1/4" - 20 lock.....	1
35	111-371	BOLT - 3/8" - 16 x 1" carriage	1
36	113-103	BOLT - 5/16" - 18 x 1"	4
37	192-20	LOCKWASHER - 5/16"	5
38	113-102	BOLT - 5/16" - 18 x 3/4"	1
39	129-102	NUT - 5/16" - 18	1
40	113-1	BOLT - 1/4" -20 x 1/2".....	2
41	192-19	LOCKWASHER - 1/4"	2
42	C37902	HOUSING ASSEMBLY - spindle (includes ref. 5, 6, 9)	3
43	219-20	FITTING - grease 1/4" - 28.....	3

* Use before S/N: 013306046

** Use S/N: 013306046 and after

INDEX

62" MOWER DECK AND ATTACHING PARTS

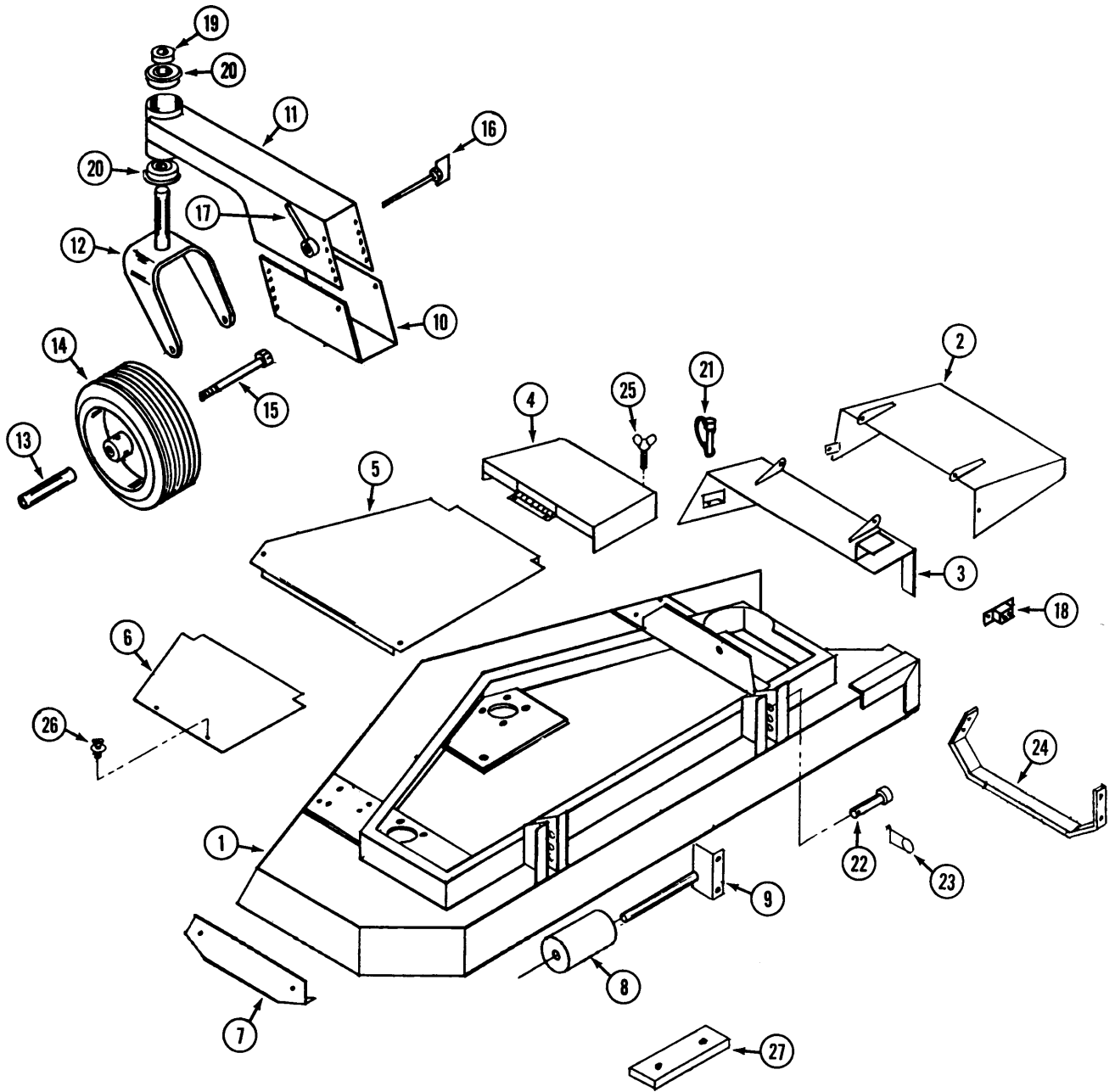

INDEX

62" MOWER DECK AND ATTACHING PARTS

REF.	PART NO.	DESCRIPTION	REQ'D
1	C44088	DECK - 62"	1
2	C41396	CHUTE - foot guard	1
3	C41400	MOUNT - foot guard.....	1
4	C41392	COVER - pulley.....	1
5	C41378	COVER - center	1
6	C41373	COVER - L.H.....	1
7	C37956	SHOE - skid L.H.....	1
8	C37910	ROLLER - anti-skid	1
9	C37911	SHAFT - roller	1
10	C37912	BRACKET - gauge wheel mount	2
11	C37913	MOUNT - gauge wheel	2
12	C37914	FORK - gauge wheel.....	2
13	C37915	AXLE - gauge wheel	2
14	C37916	WHEEL - gauge	2
	C37917	TIRE - 11 x 4.00-5	1
	C37918	RIM - 5	1
	C44499	BEARING - wheel.....	2
15	113-2419	BOLT - 1/2" - 13 x 6-1/2"	2
16	C37920	BOLT-wing	4
17	C37921	NUT - gauge wheel handle	4
18	C37505	BREAKER - circuit - 10 amp	1
19	C37860	COLLAR - set 1".....	2
20	C37824	BEARING - 1".....	4
21	C37922	PIN - "fas-tatch".....	1
22	C10821	PIN - deck.....	2
23	C29029	PIN - cotter, hair	2
24	C37957	SHOE - skid R.H	1
25	NSS	SCREW - thumb 1/4" -20 x 1/2" (use 113-3 and 192-19)	4
26	NSS	SCREW - wing 1/4" - 20 x 1" (use 113-3)	1
27	C37958	WEIGHT - tail, 13 lb	3

62" MOWER DRIVE

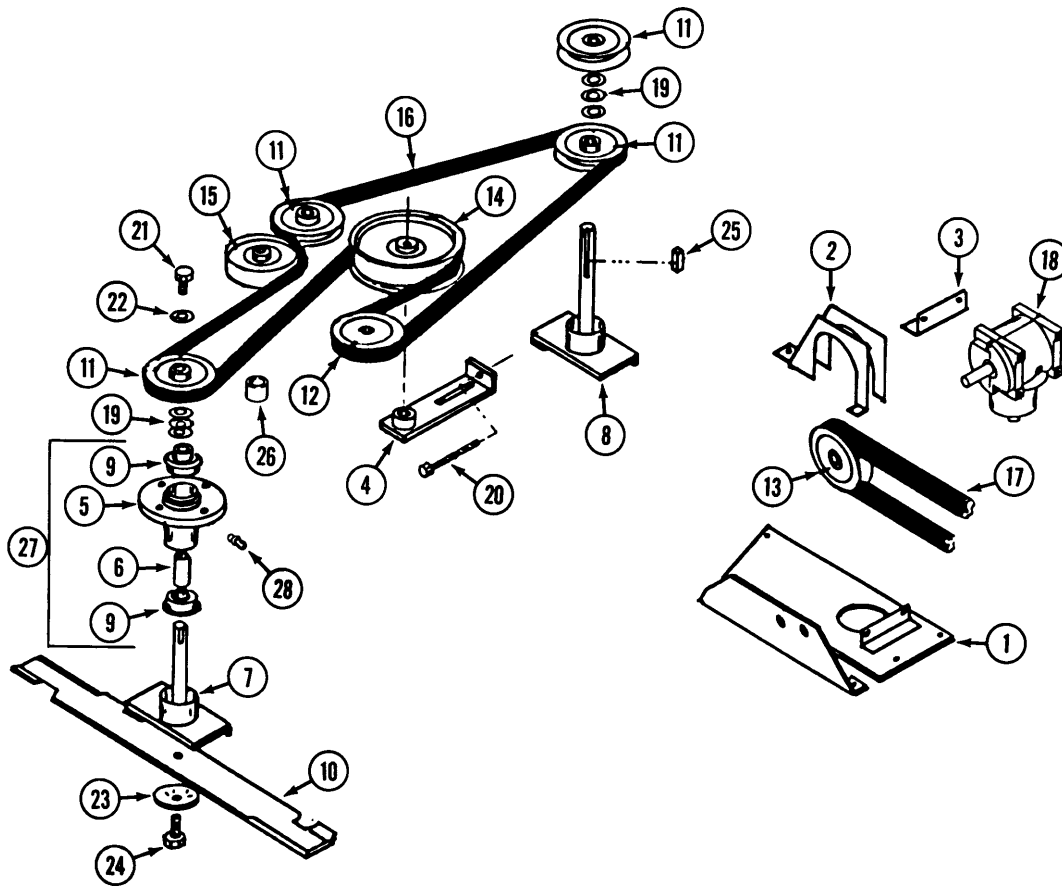

INDEX

62" MOWER DRIVE

REF.	PART NO.	DESCRIPTION	REQ'D
1	C41757	MOUNT - gearbox.....	1
2	C37875	GUARD - belt (1800SS, 1800KSS, 1890, 1890K).....	1
2	C37876	GUARD - belt (G200CII).....	1
3	C37877	ANGLE - gear box mount.....	1
4	C37929	TIGHTENER - belt.....	1
5	C37945	HOUSING - spindle.....	3
6	C37946	SPACER - spindle.....	3
7	C37947 *	SHAFT - spindle, short.....	2
7	C44132 **	SHAFT - spindle, short.....	2
8	C37948 *	SHAFT - spindle, long.....	1
8	C44134 **	SHAFT - spindle, long.....	1
9	C42786	BEARING - spindle.....	6
10	C37949 *	BLADE.....	3
10	C44138 **	BLADE.....	3
11	C37950	PULLEY - spindle.....	4
12	C37932	PULLEY - gear box output.....	1
13	C37892	PULLEY - gear box input (1800SS, 1800KSS, 1890, 1890K, 1890V).....	1
13	C37893	PULLEY - gear box input (G200CII).....	1
14	C37933	PULLEY - idler, large.....	1
15	C37934	PULLEY - idler, small.....	1
16	C38929	BELT - deck.....	1
17	C37894	BELT - drive (1800SS, 1800KSS, 1890, 1890K).....	1
17	C38566	BELT - drive (G200CII).....	2
17	C44241	BELT - drive (1890V).....	1
18	C37898	GEAR BOX - angle drive (see page 83 for service) (Curtis model).....	1
18	C42775	GEAR BOX - angle drive (see page 83 for service) (Superior model).....	1
19	C37888	WASHER - spacer.....	12
20	C37901	BOLT - 1/4" - 20 x 4".....	1
21	C39386	BOLT - 5/16" - 24 x 3/4".....	3
22	C37900	WASHER - 5/16", 10 ga.....	3
23	C37886 *	WASHER - blade.....	3
24	C37557 *	BOLT - 3/8" - 24 x 1-1/4".....	3
24	113-268 **	BOLT - 3/8" - 16 x 1" (also requires 131-1216 locknut).....	6
25	C29581	KEY - 3/16" x 3/16" x 1".....	6
26	C37937	SPACER - idler pulley.....	1
27	C37951	HOUSING ASSEMBLY - spindle (includes ref. 5, 6, 9).....	3
28	219-20	FITTING - grease 1/4" - 28.....	3

For model 62TCSS

- * Use before S/N 013306063
- ** Use S/N 013306063 and after

For model 62TCII

- * Use before S/N 013307056
- ** Use S/N 013307056 and after

INDEX

GEAR BOX (Curtis)

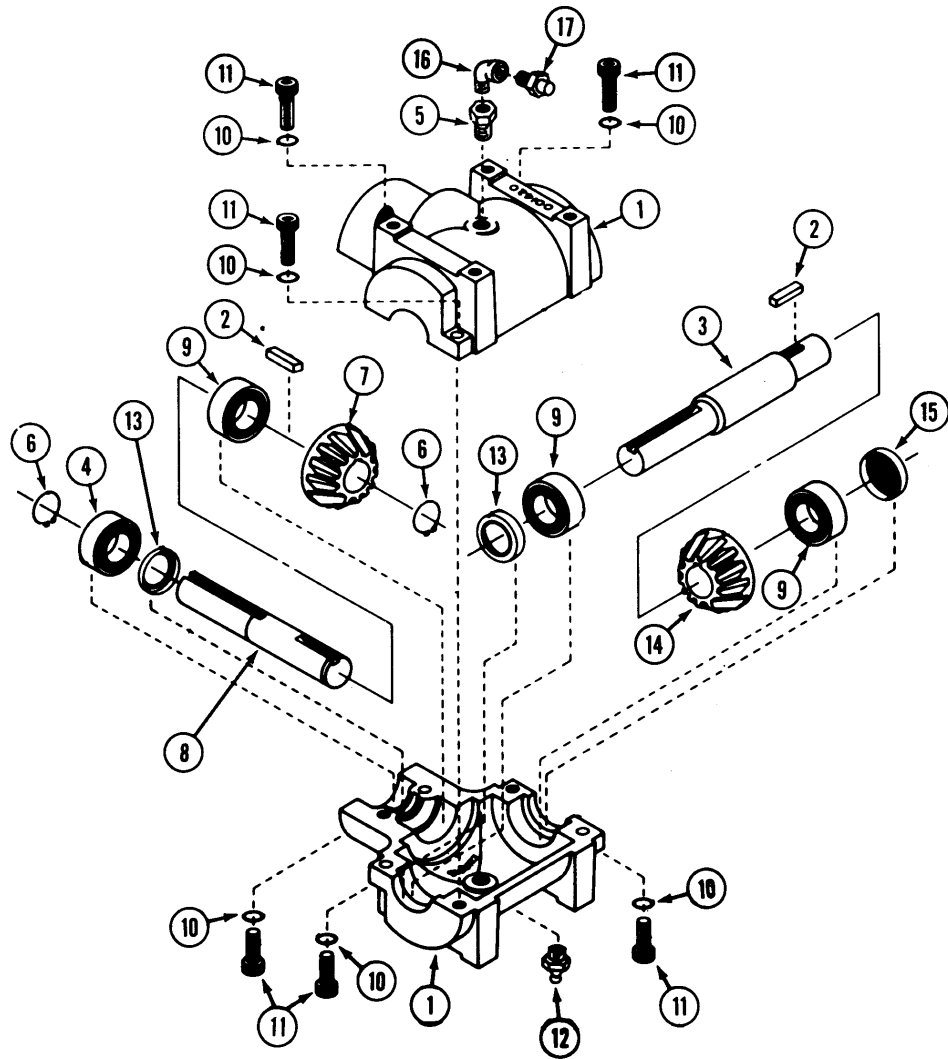

INDEX

GEAR BOX (Superior)

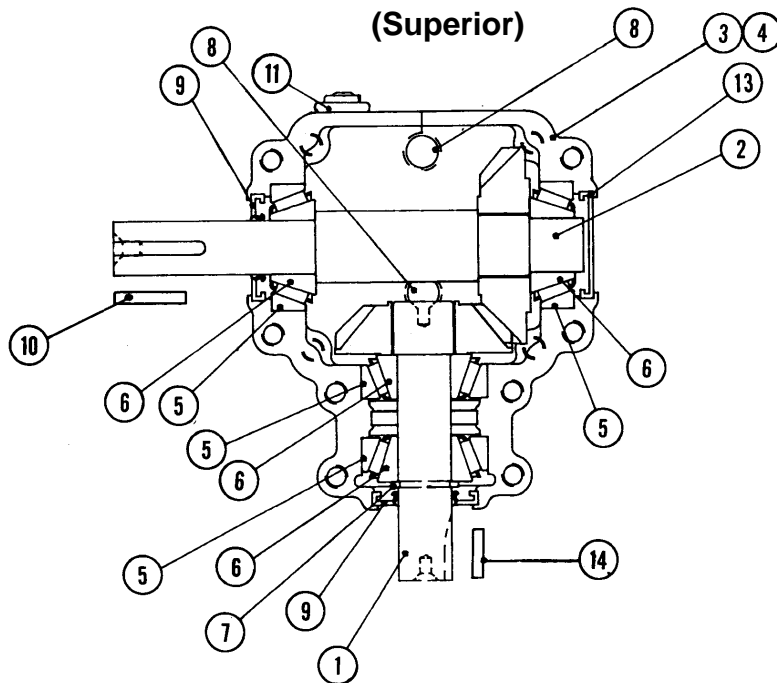

INDEX**GEAR BOX
(Curtis)**

REF.	PART NO.	DESCRIPTION	REQ'D
	C44917	GEARBOX.....	1
1	C37959	HOUSING - half.....	2
2	C29581	KEY - 3/16" x 3/16" x 1".....	2
3	C37960	SHAFT - input.....	1
4	C37961	BEARING - ball.....	1
5	221-84	BUSHING - pipe 1/4" x 1/8".....	1
6	C37963	RING - retaining.....	2
7	C37964	GEAR - output shaft.....	1
8	C37965	SHAFT - output.....	1
9	C37966	BEARING - ball.....	3
10	C37967	LOCKWASHER.....	6
11	C37968	CAP SCREW - allen head.....	6
12	219-23	FITTING - grease 1/4" NPT.....	1
13	C37969	SEAL - shaft.....	2
14	C37970	GEAR - input shaft.....	1
15	C37971	PLUG - expansion.....	1
16	221-441	ELBOW - Street 1/8" x 900.....	1
17	C28241	VALVE - relief.....	1
	C37975	GREASE - synthetic, cartridge.....	1

INDEX**GEAR BOX
(Superior)**

	NSS	GEAR BOX - (use C44917 for service).....	1
1	C42924	SHAFT - pinion, with gear.....	1
2	C42923	SHAFT - cross, with gear.....	1
3	C42917	HOUSING - with tapped holes.....	1
4	C42927	HOUSING with thru holes (not shown).....	1
5	C42918	CUP - bearing.....	4
6	C42921	CONE - bearing.....	4
7	C42919	RING - retaining.....	1
8	C42920	PLUG - pipe 1/4".....	3
9	C42922	SEAL - shaft.....	2
10	C29581	KEY - 3/16" x 1" input shaft.....	1
11	C42928	PIPE - vent.....	1
12	C42926	BOLT - 5/16" x 1" socket head (not shown).....	8
13	C42925	CAP - end.....	1
14	C28215	KEY - 3/16" x 5/8" output shaft.....	1

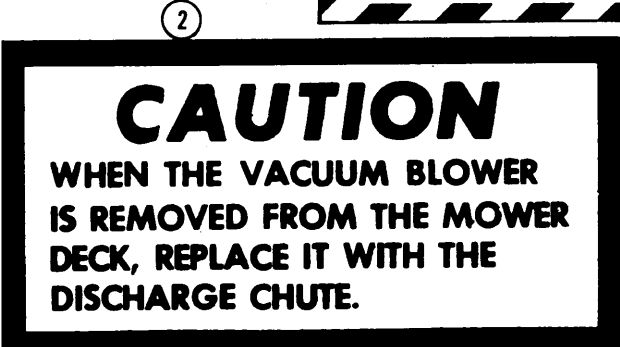

INDEX

DECALS (Deck)

REF.	PART NO.	DESCRIPTION	REQ'D
1	C37491	DECAL - "Whirling Blades"	1
2	C37492	DECAL - "Caution" discharge chute.....	1
3	C37493	DECAL - "Caution" grass chute.....	1
4	C37494	DECAL - "Danger"	1